

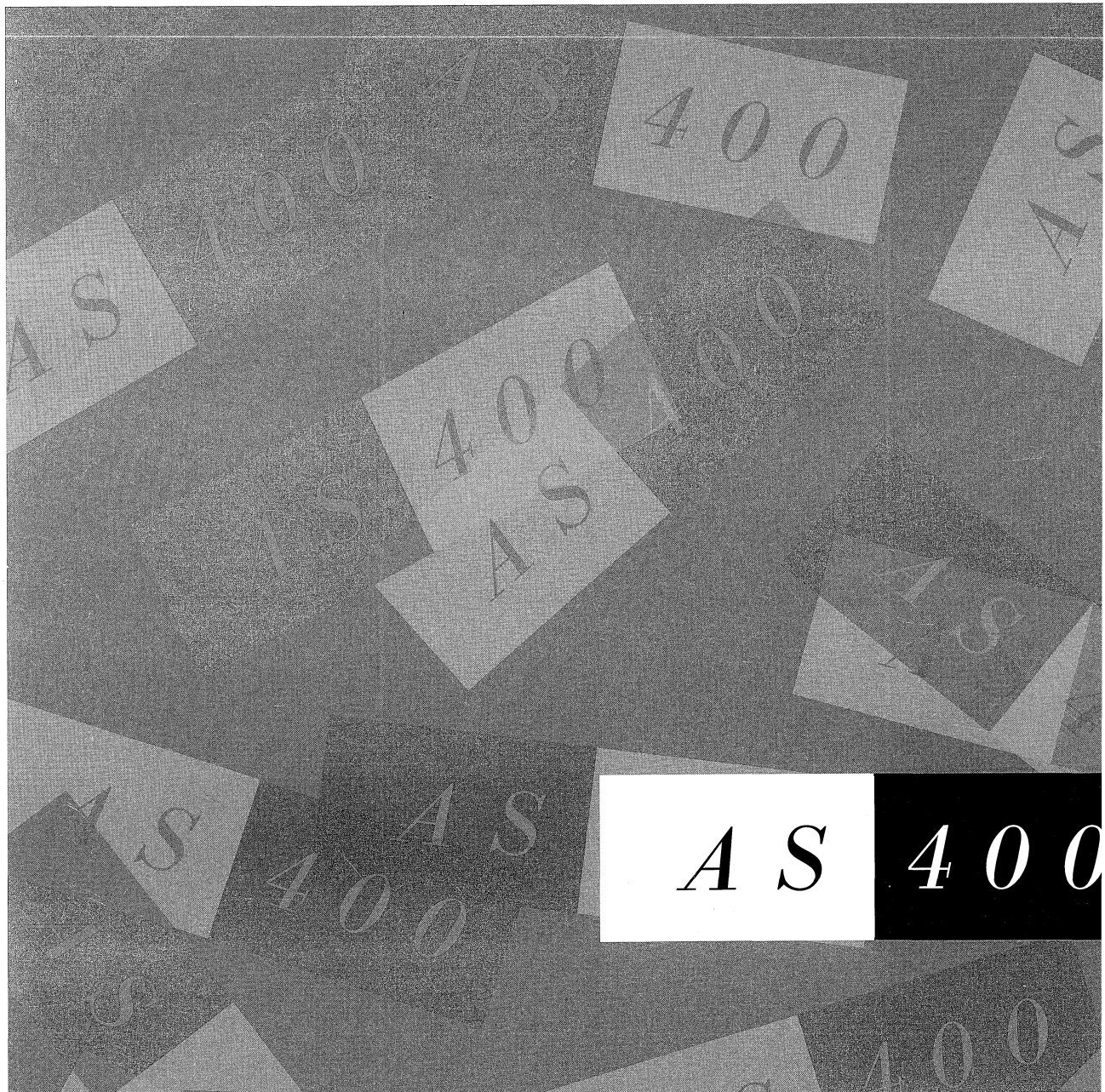

AS/400
Application Development ToolSet/400
Source Entry Utility

Version 3





AS/400

SC09-1774-00

**Application Development ToolSet/400
Source Entry Utility**

Version 3

Note!

Before using this information and the product it supports, be sure to read the general information under "Notices" on page vii.

First Edition (September 1994)

This edition applies to Version 3, Release 1, Modification Level 0, of IBM Application Development ToolSet/400 (Program 5763-PW1) and to all subsequent releases and modifications until otherwise indicated in new editions. Make sure you are using the correct edition for the level of the product.

Order publications through your IBM representative or the IBM branch office serving your locality. Publications are not stocked at the address given below.

A form for readers' comments is provided at the back of this publication. If the form has been removed, address your comments to:

IBM Canada Ltd. Laboratory
Information Development
2G/345/1150/TOR
1150 Eglinton Avenue East
North York, Ontario, Canada. M3C 1H7

You can also send your comments by facsimile (attention: RCF Coordinator), or you can send your comments electronically to IBM. See "Communicating Your Comments to IBM" for a description of the methods. This page immediately precedes the Readers' Comment Form at the back of this publication.

When you send information to IBM, you grant IBM a nonexclusive right to use or distribute the information in any way it believes appropriate without incurring any obligation to you.

© **Copyright International Business Machines Corporation 1994. All rights reserved.**

Note to U.S. Government Users — Documentation related to restricted rights — Use, duplication or disclosure is subject to restrictions set forth in GSA ADP Schedule Contract with IBM Corp.

IBM is a registered trademark of International Business Machines Corporation, Armonk, N.Y.

Contents

Notices	vii
Trademarks and Service Marks	vii
About This Book	ix
Who Should Use This Book	ix
Summary of Changes	ix
Chapter 1. Source Entry Utility Overview	1
Summary of Features	1
Authority Requirements	3
Chapter 2. Starting the Source Entry Utility	5
Starting SEU from the Programming Development Manager	5
Starting SEU from the Programmer Menu	5
Starting SEU from the Screen Design Aid	5
Starting SEU from the Command Line	5
STRSEU Command Syntax	6
Default File, Library, and Member Values for the STRSEU Command	8
Default Type and Option Values for the STRSEU Command	8
Default New Member Values for the STRSEU Command	8
Using the STRSEU Command with Parameters	9
Using the STRSEU Command with Command Prompts	9
Chapter 3. Working with Members	11
Viewing a List of Members	11
Changing the List of Members	11
Creating a Member	12
Browsing Members	15
Changing the Browse Session Environment	15
Browsing in Full Screen Mode	15
Splitting the Browse Display	16
Editing a Member	17
Special Records in the Record Field	17
Editing DDS Comments	18
Splitting the Edit Display	19
Printing a Member	20
Deleting a Member	20
How the Work with Members Using SEU Display is Processed	20
How the Edit Display is Processed	21
How an Edit Session Works	23
Chapter 4. Changing the Edit Session Environment	25
Changing the Default Case for a Member Type	26
Editing in Full Screen Mode	26
Chapter 5. Using Syntax Checking	27
Finding and Flagging Syntax Errors	27
Using Syntax Checking When Inserting or Changing Records	28
Syntax Checkers for AS/400 Source Types	29
Syntax Checkers for System/36 Source Types	29

Syntax Checkers for System/38 Source Types	30
Chapter 6. Finding and Changing Character Strings	31
Finding and Changing Strings	31
Finding Records by Date	32
Finding Syntax Errors	32
Finding a String in a List of Members Using PDM	33
Changing Strings	33
Exiting from SEU after Using Find String	34
Chapter 7. Using Line Commands	35
Sequence Numbers for Records	35
Changing the Increment Used for Sequence Numbers	35
Copying, Deleting, Inserting, Moving, and Printing Records	36
Specifying Targets	36
Copying Records	37
Copying Records Repeatedly	37
Deleting Records	38
Inserting Blank Records	38
Moving Records	39
Repeating Records	39
Printing Records	39
Entering Data	40
Displaying a Columns Line	40
Creating Prompts	40
Using Prompts for New Records – Example	41
Using Prompts for Embedded SQL Statements – Example	42
Displaying Format Lines	44
Inserting a Format Line – Example	45
Inserting Blank Lines with a Format Line – Example	46
Defining and Inserting Skeleton Lines	47
Displaying Tabs	47
Inserting a Tabs Line – Example	48
Changing the Display	49
Positioning Records on the Display	50
Excluding Records from the Display	50
Excluding Records – Example	51
Showing Excluded Records	51
Showing Excluded Records – Example	51
Rolling the Member Forward or Backward	52
Shifting the Data in Records	52
Shifting a Block of Records – Example	53
Shifting and Truncating the Data in Records	53
Controlling the Window Position	54
Changing the Horizontal Position – Example	54
Rules for Entering Line Commands	55
Performing More Than One Operation	55
Overlapping Commands	55
Pending Operations	56
Using Line Commands during Pending Operations	56
Line Command during Pending Operation – Example	56
Using Line Commands on Split Displays	57
Identifying Line Commands	58
Summary of Line Commands	59

Chapter 8. Using Source Entry Utility Commands	61
Entering SEU Commands on a Split Display	61
HIDE Command	63
FIND Command	64
CHANGE Command	65
SET Command	67
TOP Command	68
BOTTOM Command	69
SAVE Command	69
FILE Command	70
CANCEL Command	70
Chapter 9. Editing with Prompts and Format Lines	73
Command Prompts	73
Selecting Prompts	73
Selecting a High-Level-Language Prompt	74
Canceling a Prompt	75
Format Lines	76
Selecting a Format Line	77
Chapter 10. Creating Prompts	79
Creating a Prompt	79
Changing a User-Defined Prompt	80
Selecting a User-Defined Prompt	80
Defaults for Storage and Retrieval of User-Defined Prompts	81
Restricting Access to Your User-Defined Prompts	81
Creating Additional User-Defined Prompt Files	82
Chapter 11. Exiting from Source Entry Utility	83
Chapter 12. Creating a Source Member – Tutorial	85
Starting a Session with the STRSEU Command	85
Inserting Source Statements with the Insert Command	86
Inserting Source Statements with a Format Line	87
Inserting Source Statements with a Prompt	88
Saving the Member	90
Chapter 13. Changing a Source Member – Tutorial	91
Starting a Session from the Work with Members Using PDM Display	92
Changing Records Directly	92
Changing Records with a Format Line	93
Changing Records with the SEU FIND Command	94
Copying Records with the Split Edit/Browse Display	94
Changing Records with a Prompt	97
Saving the Changes	98
Chapter 14. Creating a User-Defined Prompt – Tutorial	99
Defining a Prompt Code	99
Creating a Field for the Prompt	100
Displaying and Saving the Prompt	101
Appendix A. SEU in the System/36 Environment	103
The DSU Procedure	103
How DSU Procedure Parameters Map to STRSEU Parameters	104

The SEU Procedure	104
How SEU Procedure Parameters Map to STRSEU Parameters	105
Appendix B. SEU in the System/38 Environment	107
The EDTSRC Command	107
Appendix C. Double-Byte Character Sets	109
Enabling DBCS for SEU	109
Using DBCS with SEU Displays	109
Displays That Accept DBCS Data	110
AS/400 Prompts and Fields That Accept DBCS Data	110
System/36 Prompts and Fields That Accept DBCS Data	110
System/38 and AS/400 Prompts and Fields That Accept DBCS Data	111
Considerations for Using DBCS on SEU Displays	112
DBCS in Split Displays	113
Using DBCS with SEU Commands and Functions	114
Finding and Changing DBCS Strings	114
Printing DBCS Source Data	114
Considerations for Using DBCS with SEU Commands	114
DBCS Conversion in SEU	115
When to Use DBCS Conversion with SEU	115
Considerations for Using DBCS Conversion	115
Appendix D. Recovering from Errors	117
Bibliography	119
Index	121

Notices

References in this publication to IBM products, programs, or services do not imply that IBM intends to make these available in all countries in which IBM operates. Any reference to an IBM licensed program in this publication is not intended to state or imply that only IBM's licensed program may be used. Any functionally equivalent product, program or service that does not infringe any of IBM's intellectual property rights may be used instead of the IBM product, program, or service. Evaluation and verification of operation in conjunction with other products, except those expressly designated by IBM, is the user's responsibility.

IBM may have patents or pending patent applications covering subject matter in this document. The furnishing of this document does not give you any license to these patents. You can send license inquiries, in writing, to the IBM Director of Licensing, IBM Corporation, 208 Harbor Drive, Stamford, Connecticut, USA 06904-2501.

This publication contains examples of data and reports used in daily business operations. To illustrate them as completely as possible, the examples include the names of individuals, companies, brands, and products. All of these names are fictitious and any similarity to the names and addresses used by an actual business enterprise is entirely coincidental.

At the time of printing, this book contains references to products that are announced, but may not yet be available. These products will be available later in this release.

Trademarks and Service Marks

The following terms, denoted by an asterisk (*), used in this publication, are trademarks or service marks of International Business Machines Corporation in the United States or other countries:

Application Development	IBMLink
Application System/400	ILE
AS/400	Integrated Language Environment
CICS	OS/400
CICS/400	PROFS
FORTRAN/400	SQL/400
IBM	400

The following terms, denoted by a double asterisk (**), used in this publication, are trademarks of other companies as follows:

RM/COBOL Ryan McFarland Corporation

About This Book

This book contains tutorials, instructions, and reference information that show application programmers and system programmers how to use the source entry utility (SEU). SEU is a full screen editor that you use to create and update the source members of a source file. This book contains information on:

- Starting an SEU session
- Creating, editing, browsing, and saving members using line commands, SEU commands, and the SEU displays
- Using prompts and format lines to create your own prompt
- Using the System/36 and System/38 environments, and double-byte character strings

This book also contains examples of creating and changing a source member. This book does not describe all of the functions of SEU.

You may need to refer to other IBM* publications for more specific information about a topic. The *Publications Reference*, SC41-3003, provides information on all the publications in the Application System/400* (AS/400*) library.

For a list of related publications, see the "Bibliography" on page 119.

Who Should Use This Book

This book is intended for application programmers and system programmers who work in an AS/400 environment. To use this book effectively, you must know how to use your workstation, understand and use messages, and have a general knowledge of the AS/400 system.

If you are unfamiliar with your workstation, refer to the specific book for it.

The user (described as *you* in this book) refers to the programmer working with source members in SEU.

Summary of Changes

SEU now supports the following Integrated Language Environment* (ILE*) source types:

- CBLLE (ILE COBOL). If the source file QCBLLSRC is specified, the default is CBLLE.
- CICSC (CICS C).
- CICSCBLLE (ILE COBOL with embedded CICS/400* statements or SQL statements).
- CLLE (ILE CL).
- RPGLE (ILE RPG). If the source file QRPGLESRC is specified, the default is RPGLE.
- SQLCBLLE (ILE COBOL with embedded SQL/400* statements).

- SQLRPGLE (ILE RPG with embedded SQL/400 statements).

The default case for these ILE source types is mixed. Except for CICSC, both syntax checking and prompting are supported for these source types. Except for CLLE, format lines are supported for these source types.

Margin defaults are provided for ILE RPG source types. The default left margin is 6, and the default right margin is 80.

SEU does not indicate in the sequence number area any CICS* or SQL statements that are embedded in ILE source.

Chapter 1. Source Entry Utility Overview

You can use the source entry utility (SEU) to work with source members in source physical files, and the records contained in source members.

With SEU, you can do operations such as:

- Create members
- Edit members
- Print members
- Copy records into a member from another member or spooled file

Summary of Features

SEU has the following features:

Commands

You can use SEU commands to work with the SEU environment, members, and records. You can tailor your edit session, hide records shown on the display, and save, file, or cancel changes to a member.

Format Lines

You can use format lines to verify the position of statements in high-level-language source statements. SEU provides predefined format lines for high-level languages and for AS/400 control language (CL) commands.

Full Screen Mode

You can use full screen mode on the Edit and Browse displays to remove function keys from the SEU display, providing four more lines of source.

Function Keys

Each SEU display supports a set of function keys that you use to perform specific tasks. For example, you can press F12 (Cancel) to cancel the current operation and return to the previous display. The function keys are listed at the bottom of each display. If F24 (More keys) is shown, press this key to see additional function keys for the display.

Except for F1 (Help), which is not displayed but is always valid, a function key is valid on a specific display only if it is listed at the bottom of the display. A function key may perform differently depending on the operation you are doing. If you are using SEU in full screen mode, you can use all of the function keys for that display, even though they are not shown.

You can find detailed information on function keys in the online help information for the AS/400 system. If you place the cursor on the function keys section of any display and press Help, detailed information appears.

Language and Command Prompts

You can use the SEU high-level-language or command prompts to create error-free records. When you request a language or command prompt, you can type the data for a record one field at a time. You can use the SEU-supplied prompts, or define your own.

Line Commands

You can use line commands in SEU to do many operations, such as insert blank records, copy records, and request language and command prompts.

List Displays

You can use SEU list displays to view different types of lists, as follows:

Member list	Shows all members in a specified file. Use the member list to select a member to edit, browse, print, or delete.
File list	Shows all files in a specified library. Use the file list to select a file with members that you want to edit, browse, print, or delete.
Spooled file list	Shows all spooled files for a specified user. Use the spooled file list to select a spooled file that you want to browse or copy.
User list	Shows all jobs run under all IDs. Use the user list to select the user ID from which you want to browse or copy a job. You can only access the spooled files and you may require authorization.

Maximum Number and Length of Records

SEU allows a maximum number of 32 764 records in a source member. The maximum record length SEU allows is 240 characters, which includes 6 characters for the sequence number and 6 characters for the date.

Options Displays

You can use options displays to control the SEU environment and do operations on file members and spooled files. The following options displays are used frequently in SEU:

- Change Session Defaults

Use the Change Session Defaults display to specify the characteristics of your edit or browse session.

- Browse/Copy Options

Use the Browse/Copy Options display while editing a member to look at another member or spooled file, copy another member or spooled file into the member you are editing, or copy specific records from another member or spooled file into the member you are editing.

- Find/Change Options

Use the Find/Change Options display to search for a specified string in some or all records, change a specified string in some or all records, or search for records that contain syntax errors.

Split Session Editing and Browsing

You can use split session editing and browsing to edit one member and browse another on the work display at the same time. You can also browse two members at the same time, but you cannot edit two members on the work display at the same time. If you access the Browse/Copy Options display from a split session, you can copy records from one of the members shown on the display to another member that you are editing.

Syntax Checking

You can use SEU syntax checking to verify the source statements for several high-level languages, including BASIC, PL/I, COBOL, FORTRAN, and RPG, as well as AS/400 CL programs.

System Command Window

You can enter AS/400 system commands while working on the SEU Edit display. To display the System Command window, press F21 (System command).

The System Command window avoids overlaying the cursor, so depending on the cursor location, the System Command window may appear in the top portion or in the bottom portion of the display. You cannot enter data on the SEU Edit display while the System Command window is displayed.

You cannot enter System/36 and System/38 commands in the System Command window, but you can access the Command Entry display through the Attention key.

Note: System commands such as SIGNOFF (in the AS/400 system) or ENDS36 (in the System/36 environment) end the SEU session abnormally. When you reaccess the member that you were editing, the Recover SEU Member display appears. See Appendix D, "Recovering from Errors" on page 117 for information about using this display.

Authority Requirements

The following table shows the minimum authority you need for a file before you can perform SEU operations on a file member. To add a member to a file, you require add authority for the library containing the file.

Operation	Object Authority			Data Authority				
	Object Operational Authority	Object Management Authority	Object Existence Authority	Read	Add	Update	Delete	Execute
Edit a member	X	X		X	X		X	X
Browse a member	X			X				X
Add a member	X	X		X	X		X	X
Remove a member	X		X	X				X
Revise type or text of member	X	X		X				X

For some SEU functions, you also require the authority to use CL commands such as Work with Output Queue (WRKOUTQ), Create Physical File (CRTPF), or Work with Spooled Files (WRKSPLF). If you change or replace the version of these commands that is supplied by IBM, specify the values *INTERACT and *EXEC for the new version on the ALLOW parameter of the Create Command (CRTCMD) or Change Command (CHGCMD) commands.

For further information on object authority, see *Security – Reference*, SC41-3302.

Chapter 2. Starting the Source Entry Utility

You can start SEU from:

- The programming development manager (PDM)
- The Programmer menu
- The Screen Design Aid (SDA)
- The AS/400 command line

Starting SEU from the Programming Development Manager

To start SEU from the programming development manager (PDM), select option 2 (Edit) or option 5 (Display) on the Work with Members Using PDM display.

Starting SEU from the Programmer Menu

To start SEU from the Programmer menu, select option 8 (Edit a source file member). Alternatively, select option 5 (Run a command), and select the STRSEU command from one of the lists of commands.

Starting SEU from the Screen Design Aid

To start SEU from the screen design aid (SDA), select option 2 (Edit comments) on the Work with Display Records display.

Starting SEU from the Command Line

To create, change, show, or print a source member, type the Start SEU (STRSEU) command on the AS/400 command line or on the Command Entry display.

You can use the STRSEU command to create a source member, but not to create a source file that contains source members. Use the Create Source Physical File (CRTSRCPF) command to create a source file. If you do not have a library for the source file, use the Create Library (CRTLIB) command to create one. For information about creating source files and libraries, see the *CL Reference*, SC41-3722.

You can use command prompting to enter the parameters for the STRSEU command. After typing only the STRSEU command name, or after typing the command name and some parameter values, press F4 (Prompt). The Start Source Entry Utility (STRSEU) display appears, in which you can type the remaining parameters. Press Enter to accept the default values, or type new values and press Enter to process the command.

STRSEU Command Syntax

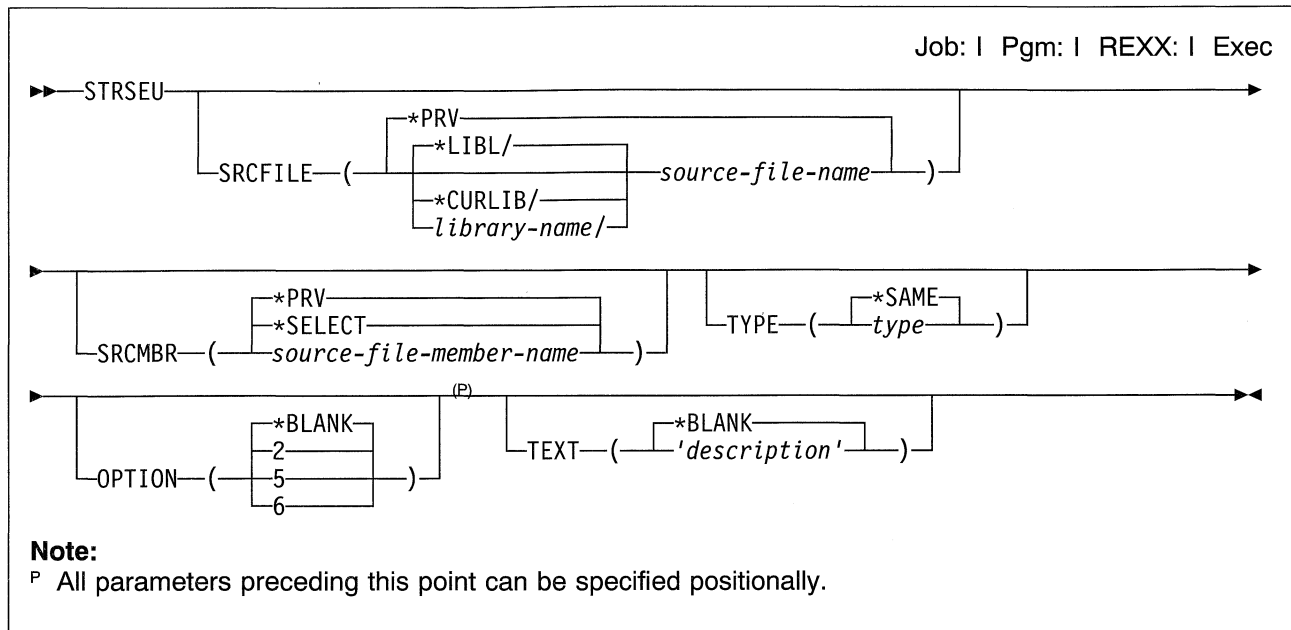

Note: Online help information is available to help you interpret the syntax diagram.

SRCFILE: Specifies the qualified name of the source physical file that contains the member being edited or created.

***PRV:** The previously specified qualified source physical file name is used.

The possible library values are:

***LIBL:** The library list is used to locate the source file.

***CURLIB:** The current library for the job is used to locate the source file. If no library is specified as the current library for the job, the QGPL library is used.

library-name: Specify the name of the library in which the source file is located.

source-file-name: Specify the name of an existing source physical file.

SRCMBR: Specifies the names of the source physical file members being edited or created. The default value for this parameter depends on whether the SRCFILE parameter is specified.

***PRV:** The previously specified source member name is used. This is the default value if *PRV is specified for the SRCFILE parameter.

***SELECT:** The SEU shows a list of members from which the user selects one to edit, show, print, or delete. This is the default value if a value other than *PRV is specified for the SRCFILE parameter.

source-file-member-name: Specify the name of the source physical file member being created or edited.

TYPE: Specifies the type of source physical file member being edited or created.

***SAME:** For members that already exist, this value indicates that the member type does not change. For members being created, this value indicates that the member type is assigned the default associated with the name of the source physical file. For the default member types for specific source file names, see “Default New Member Values for the STRSEU Command” on page 8.

type: Specify the type of source physical file member to edit. This can be any combination of up to 10 characters, or one of the following types supported by the SEU:

- AS/400 types: BAS, BASP, BND, C, CBL, CBLLE, CICSC, CICSCBL, CICSCBLE, CICSMAP, CICSSQLCBL, CL, CLD, CLLE, CLP, CMD, DFU, DSPF, FTN, ICF, LF, MENU, MNU, MNUCMD, MNUDDS, PAS, PF, PLI, PNLGRP, PRTF, QRY, REXX, RMC, RPG, RPGLE, RPT, SPADCT, SQLC, SQLCBL, SQLCBLLE, SQLCLE, SQLFTN, SQLPLI, SQLRPG, SQLRPGLE, SRT, TBL, or TXT
- System/38 types: BAS38, BASP38, BSCF38, CBL38, CL38, CLP38, CMD38, CMNF38, DFU38, DSPF38, LF38, MXDF38, PF38, PLI38, PRTF38, QRY38, RPG38, RPT38, SRT38, or TXT38
- System/36 types: ARS36, ASM36, BAS36, BASP36, BGC36, BGD36, BGF36, CBL36, DFU36, DSPF36, DTA36, FOR36, MNU36, MSGF36, OCL36, PHL36, RPG36, RPT36, SRT36, TXT36, UNS36, or WSU36

OPTION: Specifies the function to perform on the selected member. The default value depends on whether the member name is specified.

***BLANK:** This is the default value if a member name is not specified. *BLANK specifies no action; instead, a member list is

shown from which the user can specify one of the following options:

2: A member is to be edited. Option 2 is the default value if a member name is specified.

5: A member is to be displayed.

6: A member is to be printed.

TEXT: Specifies text that describes the member. This text is stored in the text field for the member. For an expanded description of this parameter, see the *CL Reference*.

***BLANK:** This is the default for a new member. This value directs SEU to specify blanks in the text field of the member. For an existing member, this value does not change the text field of the member.

'description': Specify no more than 50 characters of text, enclosed in apostrophes.

Example:

```
STRSEU SRCFILE(QGPL/FILE1) SRCMBR(TELEDIR)
TYPE(CLP) TEXT('CL program to create office
telephone directory')
```

This command starts SEU by using the source member TELEDIR in source file FILE1, which is located in the QGPL library. The TYPE(CLP) parameter indicates that this member is the source for a CL program. The TEXT parameter supplies a description of the member.

If the member exists, SEU starts an Edit session for the member. If the member does not exist, SEU creates a member with the name, type, and text specified in the command, and starts an Edit session for the member. When you create a source physical file using the CRTSRCPF command, the initial default source file is QTXTSRC. For information about creating source files and libraries, see the *CL Reference*.

Default File, Library, and Member Values for the STRSEU Command

The default values for the source file, library, and member are interdependent. The following default values are used:

File Is Specified?	Library Is Specified?	Member Is Specified?	Default for File	Default for Library	Default for Member
Yes	Yes	Yes	Supplied	Supplied	Supplied
Yes	Yes	No	Supplied	Supplied	*SELECT
Yes	No	Yes	Supplied	*PRV	Supplied
Yes	No	No	Supplied	*PRV	*SELECT
No	Yes	Yes	*PRV	Supplied	Supplied
No	Yes	No	*PRV	Supplied	*SELECT
No	No	Yes	*PRV	*PRV	Supplied
No	No	No	*PRV	*PRV	*PRV

Default Type and Option Values for the STRSEU Command

The defaults for the TYPE and OPTION parameters depend on whether or not you specify a member name. The following default values are used:

Member Is Specified?	Type Is Specified?	Option Is Specified?	Default for Type	Default for Option
Yes	Yes	Yes	Supplied	Supplied
Yes	Yes	No	Supplied	2 (Edit)
Yes	No	Yes	*SAME	Supplied
Yes	No	No	*SAME	2 (Edit)
No	Yes	Yes	Supplied	Supplied
No	Yes	No	Supplied	*BLANK
No	No	Yes	*SAME	Supplied
No	No	No	Supplied	*BLANK

Default New Member Values for the STRSEU Command

When you create a new member, the default for the TYPE parameter depends on the name of the source file in which the new member is located. The following default values are used:

Source File Name	Default for Type
QBASSRC	BAS
QCBLLSRC	CBLL
QCLSRC	CLP
QCMDSRC	CMD
QCSRC	C
QDDSSRC	PF
QFTNSRC	FTN

Source File Name	Default for Type
QLBLSRC	CBL
QMAPSRC	CICSMAP
QMENUSRC	MNUDDS
QMNUSRC	MENU
QPASSRC	PAS
QPLISRC	PLI
QPNLSRC	PNLGRP
QREXSRC	REXX
QRMCSRC	RMC
QRPGLSRC	RPGLE
QRPGSRC	RPG
QS36PRC	OCL36
QS36SRC	UNS36
QSRVSR	BND
QTBLSRC	TBL
QTXTSRC	TXT
QUDSSRC	QRY38
All Others	TXT

Using the STRSEU Command with Parameters

If you know all the parameters and values for the STRSEU command, type the entire command on the Command Entry display or the command line as in the following example and press Enter:

```
STRSEU SRCFILE(LIBRNAME01/FILENAME01) SRCMBR(MEMBNAME05) TYPE(TXT)
OPTION(2) TEXT('Customer data file for mailing list')
```

If you specify the values in the correct order, you do not have to type the names of the first four parameters. You can type the STRSEU command as in the following example:

```
STRSEU LIBRNAME01/FILENAME01 MEMBNAME05 TXT 2
TEXT('Customer data file for mailing list')
```

This is called positional coding and is described in detail in the *CL Reference*. For more information on the Command Entry display, view the online help information for the display.

Using the STRSEU Command with Command Prompts

You can use command prompts to enter the parameters for the STRSEU command. After typing only the STRSEU command name, or after typing the command name and some parameter values, press F4 (Prompt). The Start Source Entry Utility (STRSEU) display appears.

The display lists the parameters and supplies the default values. Press Enter to accept the default values, or type values for the parameters and press Enter to process the command.

Chapter 3. Working with Members

You can do the following with members:

- View a list of members
- Change a list of members
- Create a member
- Browse a member
- Edit a member
- Print a member
- Delete a member

Viewing a List of Members

To view a list of members using the STRSEU command, do one of the following:

- Specify a source file for the SRCFILE parameter but do not specify a member for the SRCMBR parameter.
- Specify the value *SELECT for the SRCMBR parameter.
- Enter the STRSEU command without any parameters if the Work with Members Using SEU display was chosen in the previous session.

The Work with Members Using SEU display appears. The display contains the information you entered for the source file and library name, the information required to create a new member, and the list of members with the specification of the list position (Bottom or More) in the bottom right-hand corner of the display.

Changing the List of Members

You can change the list of members that appears on the Work with Members Using SEU display so that only members that meet certain criteria are included. You can change the list so it shows only members that have the same:

- Partial name
- Member type
- Date of creation or last change
- Text or partial text

To change the list of members:

1. Press F17 (Subset). The Subset Member List display appears.
2. Specify the criteria for the members that you want to be in the list and press Enter. The changed list of members is displayed.

Press F1 (Help) to view the online help information about the prompts in the Subset Member List display.

Creating a Member

To create a member, do one of the following:

- From the command line, or by using command prompting, specify the name of the member to be created for the SRCMBR parameter of the STRSEU command. If you use command prompting, type a valid source type in the *Source type* prompt. If you do not, the default is used.
- On the Work with Members Using SEU display, type the name of the member to be created in the *New member* prompt, type the source type in the *Type for new member* prompt, and press Enter.

You can access the Work with Members Using SEU display by specifying *SELECT for the SRCMBR parameter of the STRSEU command.

The Edit display appears in which you can start entering source.

The following AS/400 source types are supported:

Description	Source Type
Auto report	RPT
BASIC	BAS
BASIC program	BASP
Binder Language	BND
C	C
C with embedded SQL	SQLC
C locale description	CLD
CICS C	CICSC
CICS maps	CICSMAP
CL	CL
CL program	CLP
COBOL	CBL
COBOL with embedded CICS/400* statements	CICSCBL
COBOL with embedded SQL	SQLCBL
COBOL with embedded SQL and CICS/400 statements	CICSSQLCBL
Command definition	CMD
DFU	DFU
Display	DSPF
FORTTRAN/400* member	FTN
FORTTRAN/400 member with embedded SQL	SQLFTN
ICF	ICFF
ILE C	C
ILE C with embedded SQL	SQLC
ILE CL	CLLE

Description	Source Type
ILE COBOL	CBLLE
ILE COBOL with embedded CICS/400 statements	CICSCBLLE
ILE COBOL with embedded SQL	CICSCBLLE
ILE RPG	RPGLE
ILE RPG with embedded SQL	SQLRPGLE
Logical file	LF
Menu	MNU
Menu (UIM)	MENU
Menu command source	MNUCMD
Menu DDS source	MNUDDS
Panel group source	PNLGRP
Pascal	PAS
Physical file	PF
PL/I	PLI
PL/I with embedded SQL	SQLPLI
Printer	PRTF
Query	QRY
REXX	REXX
RM/COBOL** member	RMC
RPG	RPG
RPG with embedded SQL	SQLRPG
Sort	SRT
Spelling dictionary	SPADCT
Table	TBL
Text	TXT

The following System/36 source types are supported:

Description	Source Type
Assembler	ASM36
Auto report	RPT36
Auto response	ARS36
BASIC	BAS36
BASIC program	BASP36
BGU chart	BGC36
BGU data	BGD36
BGU format	BGF36
COBOL	CBL36

Description	Source Type
Data	DTA36
DFU	DFU36
Fortran	FOR36
Menu	MNU36
Message source	MSGF36
Operator control language	OCL36
Phone list	PHL36
RPG	RPG36
SFGR format source	DSPF36
Sort	SRT36
Unspecified	UNS36
Work Station Utility	WSU36

The following System/38 source types are supported:

Description	Source Type
Auto report	RPT38
BASIC	BAS38
BASIC program	BASP38
Binary synchronous communications	BSCF38
Command definition	CMD38
Communication	CMNF38
CL	CL38
CL program	CLP38
COBOL	CBL38
DFU/38	DFU38
Display	DSPF38
Logical file	LF38
Mixed	MXDF38
Physical file	PF38
PL/I	PLI38
Printer	PRTF38
Query/38	QRY38
RPG	RPG38
Sort	SRT38
Text	TXT38

Browsing Members

You use the Browse display to view a member without the risk of accidentally changing it. You can use the scanning and positioning operations (such as Page Down and Page Up), but you cannot perform any operations that alter the member (such as adding, deleting, changing, or moving records).

To browse a member, do one of the following:

- Specify 5 (Browse) for the Option parameter on the STRSEU command.
- Select option 5 (Browse) on the Work with Members Using SEU display.

The Browse display appears containing the member that you selected.

Changing the Browse Session Environment

You can specify parameters to change the browse session environment (such as setting the amount to roll the display or forcing uppercase input) by using the Change Session Defaults display. Press F13 (Change session defaults) on the Browse display to access the Change Session Defaults display.

You can also change your browse session by using the SEU SET command. For more information, see “SET Command” on page 67.

Browsing in Full Screen Mode

Full screen mode lets you remove the format line from the top and the function key list from the bottom of the Browse display, giving you four additional Browse records to work with.

Note: The function keys are still valid for the Browse display in full screen mode, even though they are not shown.

You can use the full screen mode while browsing members or while browsing spooled files. To switch to full screen mode:

1. On the Browse display, press F13 (Change session defaults). The Change Session Defaults display appears.
2. Type Y in the *Full screen mode* prompt and press Enter. The Browse display changes to full screen mode.

To cancel full screen mode and return to the normal mode of operation:

1. On the Browse display, press F13 (Change session defaults). The Change Session Defaults display appears.
2. Type N in the *Full screen mode* prompt and press Enter. The normal Browse display appears.

Splitting the Browse Display

While browsing a member, you can split the browse display to browse another member or a spooled file. To split the Browse display:

1. Press F15 (Browse options). The Browse Options display appears.
2. Do one of the following:
 - To browse another member in the same file, type the member name in the *Browse member* prompt, and press Enter.
 - To browse another member in a different file, type the file name in the *File* prompt, type the member name in the *Browse member* prompt, and press Enter.
 - To browse a spooled file, type the spooled file name in the *Browse spool file* prompt.
 - To browse another user's spooled file, type the user name in the *User* prompt, type the spooled file name in the *Browse spool file* prompt, and press Enter.

A split line (the line separating the two browse sessions) is placed in the middle of the Browse display, and you can view the additional member or spooled file. You can move the split line by using F6 (Move split line).

Line 24 on the display contains messages for both sessions. The remaining prompts in each session of the display are the same as those on the Browse display.

Notes:

1. When you request the Browse Options display or the Find Options display from a split display, the split display is temporarily suspended. The options display that appears depends on which session the cursor is in when you press the function key.
2. For information on using SEU commands with split displays, see "Entering SEU Commands on a Split Display" on page 61.

Editing a Member

To edit a member, do one of the following:

- Specify 2 (Edit) for the OPTION parameter of the STRSEU command.
- Specify option 2 (Edit) in the *Opt* prompt on the Work with Members Using SEU display.
- Specify option 2 (Edit) on the Work with Members Using PDM display.
- Specify option 2 (Edit comments) on the Work with Display Records display in SDA.

The Edit display appears, containing the member you specified.

With the Edit display, you perform many operations, such as view the records in a member, edit the records, change the display of the member, and specify edit session defaults.

You can perform these operations by using line commands, SEU commands, or options displays. For details on using line commands to edit members, see Chapter 7, "Using Line Commands" on page 35. For details on using SEU commands to edit members, see Chapter 8, "Using Source Entry Utility Commands" on page 61.

Special Records in the Record Field

The *Record* prompt of the Edit display can contain special records. Special records exist only during the edit session and are not placed in your source member.

Special records include:

- Beginning-of-data
- End-of-data
- Format
- Insert
- Columns
- Tabs
- Exclude

Beginning-of-data and end-of-data lines are shown to designate the beginning and end of a member. You cannot remove these special records.

The following display shows an example of a partial member that contains several types of special records:

```
Columns . . . : 1 71          Edit          LIBRNAME01/FILENAME01
SEU==>          MEMBNAME01
FMT **  .... 1 .... 2 .... 3 .... 4 .... 5 .... 6 .... 7
***** Beginning of data *****
0001.00 The "Beginning of data" record above is a special record.
0002.00 This record has sequence number 0002.00.
----- 2 data records excluded -----
0005.00 The "End of data" record below is a special record.
***** End of data *****
```

Editing DDS Comments

You can use the Edit comments feature (option 2 on the Work with Display Records display) in the screen design aid (SDA) to edit record comments in display file source. Press F15 (File-level comments) to edit the file-level comments. When you specify option 2 (Edit comments) or press F15, SDA calls SEU to edit the comments.

For more information on working with display records, see *ADTS/400: Screen Design Aid*, SC09-1768.

To edit DDS comments for a specific record, do the following:

1. Type 2 (Edit comments) in the *Opt* prompt of the Work with Display Records display and press Enter to edit record-level comments. If you want to edit file-level comments, press F15 (File-level comments) instead of pressing Enter. SDA calls SEU to edit the comments, and you see the SEU Edit display.

The prompt on the right side of the title line on the SEU Edit display shows the type of DDS comment you are editing:

- *Record comments*. Displays when record-level comments are being edited. The *Record format name* is displayed in the prompt directly below.
 - *File comments*. Displays when file-level comments are being edited.
2. Add, change, or delete file-level or record-level comments as required.
 3. Save, file, or cancel your changes. You can save your changes in one of three ways:
 - Type SAVE on the SEU command line and press a positional function key (such as Enter, Page Up, Page Down, F19 (Left), or F20 (Right)) to save your changes and continue editing.
 - Type FILE on the SEU command line and press Enter to file your changes and return the Work with Display Records display in SDA.
 - Press F3 (Exit) to access the Exit display.

Type Y (Yes) in the *Save comments* prompt to have SDA save your comments made during the edit session. Type N (No) to have SDA discard any comments you made during the edit session. When you press Enter, you return to the Work with Display Records display in SDA.

The default for this prompt is Y if you made changes to the file-level comments or record-level comments, or N if you did not. You made changes if you changed, added, copied, or deleted a comment.

Note: Your comments are stored temporarily by SDA in the SDA work space when you exit the Edit comments session. The comments are not saved to the source member until you save the DDS source while exiting from SDA.

4. To cancel your changes, type CANCEL or CAN on the SEU command line, or type N in the *Save comments* prompt on the Exit display and press Enter. The Work with Display Records display is shown.

Splitting the Edit Display

While editing a member, you can split the Edit display to browse another member, a spooled file, or an output queue. You can also copy a member or spooled file into the member you are editing.

To split the Edit display:

1. Press F15 (Browse/Copy options). The Browse/Copy Options display appears.
2. Do one of the following:
 - To browse or copy another member in the same file, type the member name in the *Browse/copy member* prompt.
 - To browse or copy another member in a different file, type the file name in the *File* prompt and type the member name in the *Browse/copy member* prompt.
 - To browse or copy a spooled file, type the spooled file name in the *Browse/copy spool file* prompt.
 - To browse or copy another user's spooled file, type the user name in the *User* prompt and type the spooled file name in the *Browse/copy spool file* prompt.
3. If you want to copy the member or spooled file, type Y in the *Copy all records* prompt.
4. Press Enter. One of the following occurs:
 - If you are browsing the member, a split line (the line separating the two sessions) is placed in the middle of the Edit display, and you can view the additional member or spooled file.
 - If you are copying the member and you specified a target in the member you are editing, the member or spool file is copied into the member you are editing, but a split session is not started.

Note: See "Copying Records" on page 37 for information about copying records with line commands.
 - If you are copying the member but you did not specify a target in the member you are editing, the Edit display is split, and a Block Copy (CC) line command is placed on the first and last record of the member or spool file that you are browsing. You can then specify a target in the member you are editing. Press F12 (Cancel) to exit from the split session.

You can move the split line on a split Edit/Browse display by using F6 (Move split line).

Line 24 on the display contains messages for both sessions. The remaining prompts in each session of the display are the same as those on the Edit or Browse display.

Notes:

1. When you request a Browse/Copy display or a Find/Change display from a split display, the split display is temporarily suspended. The options display that appears depends on which session the cursor is in when you press the function key.
2. For information on using SEU commands with split displays, see “Entering SEU Commands on a Split Display” on page 61.

Printing a Member

To print a member, do one of the following:

- Specify 6 (Print) for the OPTION parameter of the STRSEU command.
- Select option 6 (Print) on the Work with Members Using SEU display.
- When you exit from an edit session, type Y in the *Print member* prompt on the Exit display.
- When you browse or edit a member, use the Line Print line command. See “Printing Records” on page 39 for more information on the Line Print line command.

Note: When you print a member with a large logical record length, it is not printed with triple spacing.

To print a member with triple spacing, ensure that the actual record length is greater than 100 characters, and that the logical record length is equal to the record length of the file minus 12. For example, if the record length of the file is 132, set the logical record length to 120. Otherwise, the member is printed using the actual record length.

Change the logical record length using either the Edit System/36 Source Attribute (EDTS36SRCA) or the Edit System/36 Procedure Attribute (EDTS36PRCA) command.

Deleting a Member

To delete a member, select option 4 (Delete) on the Work with Members Using SEU display.

The Confirm Delete of Members display appears, which lists all the members that you marked to be deleted. Check the list carefully to ensure that you are deleting the correct members.

How the Work with Members Using SEU Display is Processed

SEU processes the Work with Members Using SEU display as follows:

1. When you press the Page Up or Page Down keys, or perform a reposition request, SEU begins processing by checking the display for errors.

If errors exist, SEU highlights them and lists the appropriate error messages. If no errors occur, SEU processes the page or reposition request.

2. When you press Enter, SEU checks for errors. If no errors occur, SEU begins processing the options on the display.
 - a. If you have changed the source file or library name, SEU checks for pending options in the list and for a new member name.

If there are no pending options, or if a new member name has not been specified, SEU changes the list to show the members in the new source file or library. If there are pending options, or if a new member name is specified, SEU issues an error message.
 - b. If you did not change the source file or library name, SEU checks the *Position to* prompt.

If you specified a value for this prompt, SEU repositions the list as requested, then processes any options you specified.
 - c. SEU begins processing all options on the display in the order they occur. When it finds a delete option, SEU shows the Confirm Delete of Members display. This display lists all members marked for deletion on the Work with Members Using SEU display. Confirm that each delete choice is correct, or return to the Work with Members Using SEU display to change your choices.

If you confirm all delete choices, SEU returns the Work with Members Using SEU display and performs the delete choices. It then continues to process the remaining options on the display in the order they occur.
 - d. If you press F17 (Subset), SEU checks for pending operations in the member list. If there are pending operations, SEU issues an error message.

How the Edit Display is Processed

SEU processes the Edit display in the following order:

1. Processes Clear and Home operations: this removes all input typed in since the last key was pressed, and immediately shows the Edit display.
2. Refreshes the display (F5): this immediately shows the Edit display without a prompt, temporary lines, pending line commands, or SEU commands, and removes all input typed in since the last key was pressed.
3. Shows additional function keys (F24).
4. Enters changes to records.
5. Enters changes to prompts in a prompt.
6. Enters changes to insert lines.
7. Performs syntax checking on the data records.
8. Parses line commands and SEU commands: severe line commands or SEU command errors cause the display to be shown again without further processing of this list.
9. Processes continuous insert.
10. Processes all line commands.
11. Processes all SEU commands.
12. Starts a prompt (F4).

13. If a prompt is active and a prompt line command is not entered:
 - Places the next record in a prompt when you press Enter.
 - Places the previous record in a prompt (F11).
14. If a prompt is active:
 - Presents the Select Prompt display (F23).
 - Cancels the prompt (F12).
15. Removes the split display (F12).
16. Processes the Page Up, Page Down, F19 (Left), and F20 (Right) keys.
17. Sets the new starting position of the find and change operation, if required.
18. Processes the F13 (Change session defaults), F14 (Find/Change options), and F15 (Browse/Copy options) keys.
19. Performs any F16 (Repeat find) and F17 (Repeat change) operations.
20. Repositions the display to show the result of the find and change operation.
21. If the display has not been repositioned:
 - Repositions for continuous inserting, if required.
 - Repositions for continuous prompting. If the record is no longer on the screen, SEU removes the prompt, if required.
22. Determines whether a prompt is still shown.
23. Quits the SEU session (F3).

System/38 commands and System/36 commands are not performed in SEU, but you can access the Command Entry display by using the Attn key to enter these commands.

Errors are placed in a list in the order in which they are encountered, with the exception of syntax errors. Syntax errors are placed last on the list.

In situations where different items affect the same function, SEU processes the last item on the list. For example, if all the following are in effect, only the Page key takes effect:

- The display must roll to show the next line for the prompt
- You enter a line command to position the display
- You press Page Up or Page Down

The other functions are preempted.

How an Edit Session Works

The following diagram shows the steps that SEU uses to process data when you are editing source members:

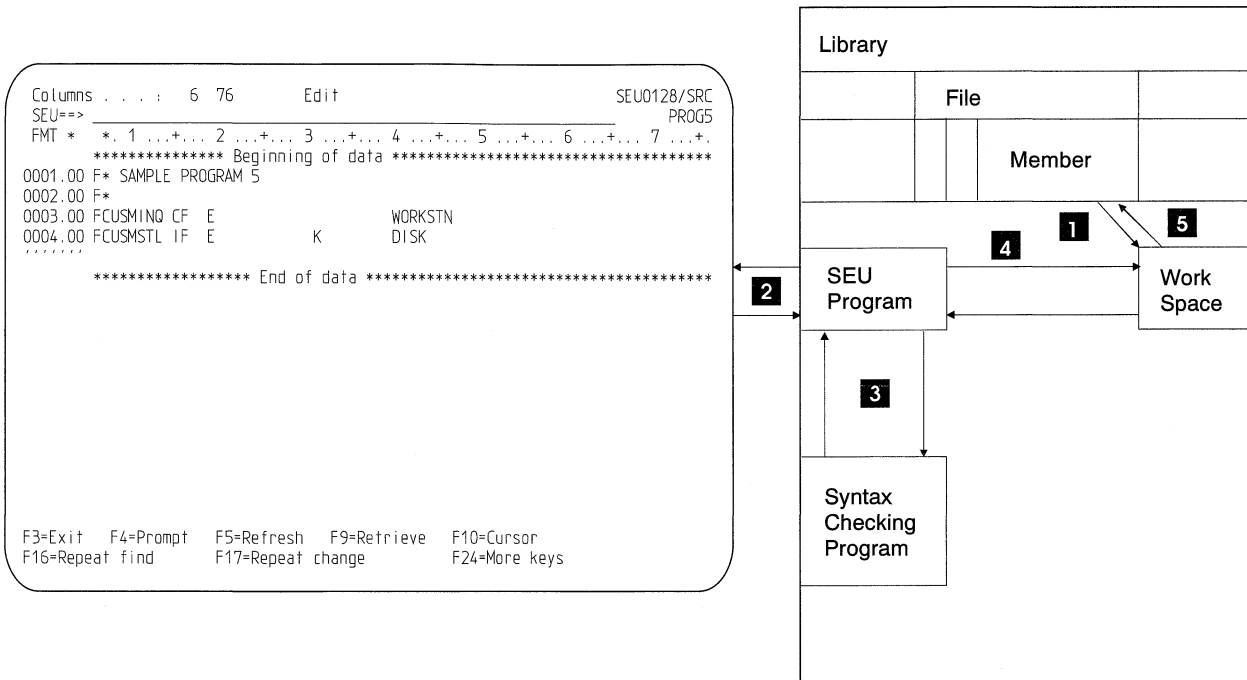

QSU3003

- 1** A copy of the member is placed in a work space when an edit session is started.
- 2** The records are displayed at the workstation so you can add new source records and change existing source records.
- 3** New and changed source records are optionally checked by a syntax-checking program.
- 4** The new or changed records are placed in the work space.
- 5** The records are optionally resequenced, and are transferred from the work space to the source member when you exit from editing.

Chapter 4. Changing the Edit Session Environment

You can change the edit session environment by using the Change Session Defaults display or the SEU SET command.

To change the edit session environment using the Change Session Defaults display, press F13 (Change session defaults) on the Edit display. The Change Session Defaults display appears.

You can do the following using the Change Session Defaults display:

- Specify the amount by which the data is rolled
- Specify uppercase only or mixed-case input
- Turn tabs on or off
- Specify the amount to increment sequence numbers for inserted records
- Turn full screen mode on or off
- Specify the screen size (for 27 row X 132 column displays only)
- Specify the type of the source member that you are editing
- Turn syntax checking on or off
- Specify syntax checking for a range of statements
- Set margins
- Set all existing records to a specific date
- Set the resequence member default
- Change the default input case for a source type

Some default values are dependent on the source type of the member, while others are dependent on the value you entered and used during the last edit session. If there is an error in the input, the incorrect input is highlighted. You must correct the error before you can save the prompts.

Each of the preceding tasks corresponds to a prompt on the Change Session Defaults display. For information on each prompt, press F1 (Help) to see the online help information for the Change Session Defaults display.

You can use the SEU SET command to change some session defaults. Options entered through the SET command appear in the corresponding prompts on the Change Session Defaults display. You can use the SET command to do the following for the edit session:

- Specify the amount by which the display is rolled
- Specify uppercase only or mixed-case input
- Turn tabs on or off
- Turn full screen mode on or off

For more information on the SET command, see Chapter 8, "Using Source Entry Utility Commands" on page 61 and "SET Command" on page 67.

Changing the Default Case for a Member Type

The default case used depends on the source type. To change the default case setting for a member type, do the following:

1. Edit a member of the type that you want to change.
2. Press F13 (Change session defaults).
3. Press the Page Down key to access the second part of the Change Session Defaults display.
4. Type either of the following in the *Default to uppercase input for this source type* prompt:
 - Y (Yes) to assign the current source member type an uppercase input default for the current and subsequent edit sessions
 - N (No) to assign the current source member type a mixed-case input default for the current and subsequent edit sessions

Editing in Full Screen Mode

With full screen mode, you can remove the format line from the top and the function key list from the bottom of the Edit display, providing four additional Edit records with which to work. If you use SEU language prompts, they are displayed in an abbreviated form. For example, the *Prompt type* prompt is shown as the *Pmt* prompt.

Note: The function keys are still valid for the Edit display in full screen mode, even though they are not shown.

To switch to full screen mode, press F13 (Change session defaults) on the Edit display to access the Change Session Defaults display, and type Y in the *Full screen mode* prompt.

To cancel full screen mode and return to the normal mode of operation in SEU, press F13 (Change session defaults) to access the Change Session Defaults display, type N in the *Full screen mode* prompt, and press Enter. SEU returns the normal Edit display. If you use SEU language prompts, full language prompts appear.

For information on how to use the SET command to switch to full screen mode, see “SET Command” on page 67.

Chapter 5. Using Syntax Checking

You can do syntax checking of high-level-language (HLL) and control language (CL) source statements to help you create source members free of syntax errors.

You can use the syntax checking feature of SEU in two ways:

- To find syntax errors in a range of records
- To check records for syntax errors as you insert or change them

When a syntax error is found in a line, SEU flags it by displaying the line in reverse image, and issues an error message. The source type of the member you are editing determines the syntax checker that is used.

Note: Syntax checking performed by SEU is not meant to replace the more comprehensive syntax checking performed by language processors. The scope of a source member that is syntax checked is limited to single records or statements only. Errors in identifier references or procedure calls are examples of syntax-related issues that are not dealt with by the syntax checker in SEU.

You can also search for records added or changed that contain syntax errors. For information, see “Finding Syntax Errors” on page 32.

Finding and Flagging Syntax Errors

To find and flag syntax errors in a member, do the following:

1. Start an SEU edit session with the member you want to check.
2. Press F13 (Change session defaults) to access the Change Session Defaults display.
3. Verify that a syntax checker exists for the source type of the member you are editing. If the source type shown in the *Source type* prompt does not have a syntax checker, you cannot perform this function.
4. Specify two sequence numbers in the *From sequence* and *To sequence* prompts as a range of records to check. When you specify the starting and ending sequence numbers, SEU checks the syntax of all records in the member you are editing within the range specified by the two sequence numbers. If you specify 0 for the *From sequence* prompt, 9999.99 for the *To sequence* prompt, or a line number greater than the member size for the *To sequence* prompt, SEU checks all records in the member for syntax errors.
5. Verify the default values for the portion of each record to check in the *Left margin* and *Right margin* prompts if you are editing a PL/I member. Press Enter.

SEU checks all lines within the range you specified on the Change Session Defaults display. If there is a syntax error in a line, SEU flags the error by displaying the line in reverse image, and issues an error message. If there is more than one error in a line, SEU deals with each error, moving from left to right across the line.

Using Syntax Checking When Inserting or Changing Records

To use the syntax-checking feature of SEU when inserting or changing records in a member, do the following:

1. Start an SEU edit session with a new or an existing member.
2. Press F13 (Change session defaults) to access the Change Session Defaults display.
3. Verify that a syntax checker exists for the source type of the member you are editing. If the source type shown in the *Source type* prompt does not have a syntax checker, SEU displays an error message and you cannot perform this function.
4. Type Y (Yes) in the *When added/modified* prompt in the Syntax Checking section of the display to have SEU check each line for syntax errors as you add or change it.
5. Verify the default values for the portion of each record to check in the *Left margin* and *Right margin* prompts if you are editing a PL/I, C, SQLC, or SQLPLI member. Press Enter to return to the Edit display.
6. Insert a new record by using the Insert (I) or Insert-with-Prompt (IP) line commands, or make changes to an existing record. Press Enter.

SEU checks the line you added or modified for syntax errors. If there is a syntax error in the line, SEU flags the error by displaying the line in reverse image, and issues an error message. If there is more than one error in a line, SEU deals with each error, moving from left to right across the line.

If you type Y (Yes) in the *When added/modified* prompt, errors are flagged only on lines that you add or change in the current edit session. If you edit a member that was saved in a previous edit session, lines that contained syntax errors from that session are flagged only if:

- They are changed in the current session.
- You specify a range of records to check on the Change Session Defaults display.
- A modified record affects its surrounding records.

Note: Depending on the programming language you are using, a modified record may cause the syntax checker to check all statements that are logically complete. See the applicable language manual for details on how syntax checking is done for the language you are using.

You can syntax-check records while you are using a prompt or a format line. If you are using a prompt, SEU checks for syntax errors while the record is in the prompt. If there are errors, the record is retained in the prompt, and a message is issued. You can correct the error at this time, or press Enter to tell SEU to insert the record into the member anyway.

Syntax Checkers for AS/400 Source Types

Syntax checkers for the following AS/400 source types are provided by IBM in library QSYS:

BAS	CL	LF	RPGLE
BASP	CLLE	MNU	RPT
BND	CLP	MNUDDS	SQLCBL
CBL	CMD	PF	SQLCBLLE
CBLLE	DFU	PLI	SQLFTN
CICSCBL	DSPF	PRTF	SQLPLI
CICSCBLLE	FTN	QRY	SQLRPG
CICSSQLCBL	ICFF	RPG	SQLRPGLE

The following AS/400 source types do not have syntax checkers:

C	MENU	REXX	SQLCLE
CICSC	MNUCMD	RMC	SRT
CICSMAP	PAS	SPADCT	TBL
CLD	PNLGRP	SQLC	TXT

Syntax Checkers for System/36 Source Types

Syntax checkers for the following System/36 source types are provided by IBM in library QSYS: CBL36, RPG36, and RPT36.

The following System/36 source types do not have syntax checkers:

ASM36	BGD36	FOR36	SRT36
ARS36	BGF36	MNU36	UNS36
BAS36	DFU36	MSGF36	WSU36
BASP36	DSPF36	OCL36	
BGC36	DTA36	PHL36	

Syntax Checkers for System/38 Source Types

Syntax checkers for the following System/38 source types are provided by IBM in library QSYS:

BAS38	CLP38	LF38	QRY38
BASP38	CMD38	MXDF38	RPG38
BSCF38	CMNF38	PF38	RPT38
CBL38	DFU38	PLI38	
CL38	DSPF38	PRTF38	

The following System/38 source types do not have syntax checkers: SRT38 and TXT38.

Chapter 6. Finding and Changing Character Strings

During an edit session, you can search a member for a string of characters, and optionally change that string to a new string, by using the Find/Change Options display.

To access the Find/Change Options display, press F14 (Find/Change options) while on the Edit display. You can do the following on the Find/Change Options display:

- Find a specified string
- Change a specified string
- Find records with a specified date
- Find syntax errors

During a browse session, you can search for a string of characters by using the Find Options display. The Find Options display is similar to the Find/Change Options display. You cannot change a member using the Find Options display, and you cannot find syntax errors, except in a spooled file.

You can perform most of the functions on the Find/Change Options display and the Find Options display by using the SEU FIND, CHANGE, and SET commands. See Chapter 8, "Using Source Entry Utility Commands" on page 61 for information on the SEU FIND, CHANGE, and SET commands.

To save the values you enter for the *Find* prompt and the *Change* prompt, press Enter, F16 (Find), or F17 (Change). If the input contains no errors, the values for all prompts are saved, except for the *Occurrences to process* prompt, and the values are displayed the next time you call the Find/Change Options display.

Finding and Changing Strings

To find a string:

1. Type the string you want to find in the *Find* prompt of the Find Options display or the Find/Change Options display.
2. Change the other prompts, if necessary.
3. Press F16 (Find). The string is found.

To find and change a string:

1. Type the string you want to change in the *Find* prompt of the Find/Change Options display.
2. Type the string you want to replace it with in the *Change* prompt.
3. Change the other prompts, if necessary.
4. Press F17 (Change). The occurrences of the string that you specified are changed.

Note: For help on any of the prompts on the display, press F1 (Help) to display the online help information.

If the string you type for the *Find* or *Change* prompt is enclosed in quotation marks or apostrophes, the quotation marks and apostrophes are ignored for the search.

Otherwise, the string begins in the first position and includes all characters up to and including the last nonblank character. Enclose the string in quotation marks or apostrophes to include beginning and ending quotation marks, apostrophes, and trailing blanks. Two quotation marks adjacent to each other define the null string.

The following table shows how to find strings, including strings with quotation marks, apostrophes, and blanks.

To Find This String	Specify This String
ABC	ABC or 'ABC' or "ABC"
'ABC'	' 'ABC' ' or "'ABC'"
'ABC	'ABC or ' 'ABC' or "'ABC"
ABC'	ABC'
b'ABC'b	'b'ABC'b' or "b'ABC'b"
O'NEIL	O'NEIL or 'O'NEIL' or "O'NEIL"
bbbbABC	bbbbABC
ABCbbbb	'ABCbbbb' or "ABCbbbb"
ABCbDEF	ABCbDEF or 'ABCbDEF' or "ABCbDEF"
*ERR	'*ERR' or "*ERR"
*	'*' or "*"

Note: b=blank

To search for an asterisk (*) character in a member, enclose it in quotation marks when you type it as the find string. Otherwise, SEU interprets the asterisk as a request to search for the previous find string. This is only valid for the SEU FIND and CHANGE commands if strings were entered previously.

Finding Records by Date

To find a record last changed on a specified date:

1. Press F14 (Find options) to access the Find Options display.
2. Specify the date in the *Search on date* prompt.
3. Specify 1, 2, or 3 in the *Compare* prompt.
4. Press F16 (Find). The record with the specified date is found. Use F16 (Repeat find) to find the next record with the specified date.

Searching for a date and searching for the find string are mutually exclusive. The *Compare* prompt determines which type of find is performed when you press F16 (Find). If the *Compare* prompt is blank, SEU searches for the find string. If the compare prompt is not blank, SEU searches for the date.

Finding Syntax Errors

You can use the find operation to locate syntax errors detected in a source member by an SEU syntax checker. To find syntax errors, type *ERR in the *Find* prompt, leaving the remainder of the prompt blank. When you press F16 (Find), SEU locates any syntax errors found by the syntax checker.

Note: To search for the string *ERR in a member, enclose it in quotation marks when you type it as the find string. Otherwise, SEU interprets the asterisk as a request to search for syntax errors.

When searching for syntax errors, the find parameters (*Occurrences to process* and *Records to search* prompts) function the same as for a normal find. You cannot perform a change operation with a find operation that specifies syntax errors.

See Chapter 5, “Using Syntax Checking” on page 27 for details on how to set up syntax checking in your edit session.

For information on using the FIND command to locate syntax errors, see “FIND Command” on page 64.

Finding a String in a List of Members Using PDM

You can use the find string function (option 25 on the Work with Members Using PDM display) of the programming development manager (PDM) to search selected members in a list or a subset of a list for a character string. You can use an option of the find string function to use SEU for editing members that contain the string you specify. For more information on using the find string function of PDM, refer to the *ADTS/400: Programming Development Manager*, SC09-1771.

If you specify 2 (Edit) for the *Option* prompt on the PDM Find String display, PDM calls SEU to edit the selected members in the list that contain the string you specify. Also, PDM passes the values for the *Find Columns to search* and *Kind of Match* prompts to the Find/Change Options display of SEU each time it calls SEU.

When SEU starts, the cursor is positioned on the first occurrence of the find string. Press F16 (Find) to find each subsequent occurrence.

Changing Strings

You can use SEU to replace the string you specified in the *Find* prompt with another string. To change strings located with the PDM find string function, do the following:

1. Select the members you want to search by using option 25 (Find string) on the PDM member list and press Enter. The Find String display is shown.
2. Specify values for the *Find*, *From column number*, *To column number* and *Kind of match* prompts. These values are used for each member selected for the search.

You may also specify values for the print options. These allow you to print either the list of members which contain the find string, or the records in the member which contain the match. For more information on the print options, refer to *ADTS/400: Programming Development Manager*.

3. Type 2 in the *Option* prompt, and press Enter. PDM searches the members you selected for the string specified in the *Find* prompt. If PDM finds the string, it calls SEU to edit the member. SEU positions the member so that the cursor is under the first occurrence of the string.
4. Press F14 (Find/Change options) to access the Find/Change Options display.

Use the Find/Change Options display to specify the options for the change operation.

Note: The *Find*, *From column number*, *To column number*, and *Kind of match* prompts are already filled in with the values you specified on the Find String display.

5. Press F17 (Change) to perform the change operation.

If you specified 2 (All) for the *Occurrences to process* prompt, SEU changes all of the strings in the member to the one you specified. If you specified 1 (Next) or 3 (Previous), press F17 to change following or previous strings one at a time.

6. Press F3 (Exit) to access the Exit display when you finish changing the member. Type Y in the *Create/Change member* prompt, then press Enter to save the changes.

The programming development manager (PDM) continues to search the remaining members you selected for the find string.

Notes:

1. All of the values you specified on the PDM Find String display are retained for each of the members searched. For example, the value you type in the *Find* prompt is used to search all of the members that you select.
2. The value you specify for the *Change* prompt on the SEU Find/Change Options display is retained from the first change operation you perform. When PDM calls SEU for another member that contains the *Find* string, you can press F17 (Repeat change) to perform the same type of change as you did for the previous member.

If you specify 2 (All) for the *Occurrences to process* prompt, this value is also retained for subsequent change operations. If you specify any other value for the *Occurrences to process* prompt, this prompt assumes the value 1 (Next) for each subsequent member.

3. The value you specify for the *Allow data shift* prompt on the Find/Change Options display in SEU is not retained for future edit sessions when you use the Find String function. The default for this value depends on the type of the source member being edited.

Exiting from SEU after Using Find String

When you exit from an edit session, you can continue searching the remaining members you selected on the Work with Members Using PDM display, or you can cancel the search and return the Work with Members Using PDM display.

To exit from SEU while in an edit session, press F3 (Exit). If you want to continue searching members for the find string, type N in the *Cancel PDM Find String* prompt, then press Enter. If you want to cancel the search for the find string, type Y in this prompt. N is the default for this prompt.

You can also press F3 (Exit) twice to cancel the search for the find string. Any changes you made to the member are discarded.

Chapter 7. Using Line Commands

You can use SEU line commands to perform various functions on the records in a member. You can use line commands to:

- Copy, delete, insert, move, or print records
- Help you enter and format data for new records
- Change which records you see on the display

You type line commands in the *Sequence number* field for a record. For example, type the D (delete) line command in the sequence number of a record to delete that record. Type the D3 line command to delete three records.

You can type these commands in uppercase or lowercase. SEU automatically converts the commands to uppercase.

After typing or changing your line commands, press one of the following keys to run the commands:

- Enter
- A valid function key
- Page Up or Page Down

Sequence Numbers for Records

As you enter source statements into a member, SEU assigns a unique sequence number to each record.

When you create a new source member or add records to the end of an existing member, SEU uses a 1.00 increment to assign sequence numbers. For example, SEU numbers the first records in a new source member as follows:

```
0001.00
0002.00
0003.00
.
.
.
000n.00
```

When you copy, move, or insert records, SEU uses 0.01 increments. For example, if you insert three records between records 0003.00 and 0004.00, SEU assigns sequence numbers 0003.01, 0003.02, and 0003.03 to the inserted records.

Changing the Increment Used for Sequence Numbers

To change the increment SEU uses for inserted records, specify the increment you want on the *Increment of insert record* field on the Change Session Defaults display.

If you specify an increment greater than 1.00, the sequence number for each record inserted is incremented by that amount.

If you specify an increment less than 1.00, the sequence numbers for the records inserted before the end of the member are incremented by that amount, while those added to the end of the member are incremented by 1.00.

SEU resequences the records when you add a record between two consecutively numbered records (for example, between records 1.01 and 1.02). SEU also resequences the records if you copy or move a group of records to a target location that cannot receive all the records.

Copying, Deleting, Inserting, Moving, and Printing Records

To copy, delete, insert, move, or print records in a member, use the following types of line commands:

- After, Before, and Overlay (target commands)
- Copy
- Copy Repeat
- Delete
- Insert
- Move
- Repeat
- Line Print

Specifying Targets

The After (A), Before (B), and Overlay (O) commands are target commands. You specify the After, Before, or Overlay command as a target for a Copy (C), Copy Repeat (CR), Move (M), or block (MM, CC) command.

The Overlay command replaces blank data in a selected line with nonblank data from another line. The Overlay command selects the target, or the line whose blanks are replaced. The Copy, Copy Repeat, and Move commands select the line that replaces the blanks.

Use the following line commands to specify a target:

Command	Description
A	Move, copy, or insert the specified records after this record.
An	Move, copy, or insert the specified records after this record and repeat the lines $n-1$ times.
B	Move, copy, or insert the specified records before this record.
Bn	Move, copy, or insert the specified records before this record and repeat the lines $n-1$ times.
O	Overlay this record with the first record specified by the Copy, Copy Repeat, or Move line command.
On	Overlay this record and the next $n-1$ lines with the records specified by the Copy, Copy Repeat, or Move line command.
OO	Overlay all records in this block (defined by a pair of OO commands) with the records defined by the Copy, Copy Repeat, or Move line commands.

Note: When you use the Overlay line commands, keep the following in mind:

- If you specify more records to overlay than you are copying or moving, SEU reuses the moved or copied records to complete the overlay.
- The records to be moved are deleted from their original location after the overlay is performed, unless one of the following is true:
 - There are more records to overlay than to move.
 - Not all nonblank characters from the move records are copied to the overlay records.

In either situation, SEU retains the records in their original position and issues a message.

For examples of using the target commands, see “Copying Records,” “Copying Records Repeatedly,” and “Moving Records” on page 39.

Copying Records

You can copy a record or block of records to another location in a member or to another member with the following line commands:

Command	Description
C	Copy this record to the target specified by A, B, O, or OO.
CC	Copy this block of records (defined by a pair of CC commands) to the target specified by A, B, O, or OO.
Cn	Copy <i>n</i> records, starting with this record, to the target specified by A, B, O, or OO.

You can type the line commands for a copy operation in any order. For example, you can type the target (A, B, or O) line command before or after typing the CC and CC line commands that identify the block of records to be copied, but the target must be outside the range of the block command. For more information, see “Rules for Entering Line Commands” on page 55.

Copying Records Repeatedly

You can repeatedly copy a record or block of records to one or more locations by using the Copy Repeat (CR) command. This command is used with the target commands, similar to the way you use the Copy command. After processing the operation, SEU removes the target commands but retains the CR command on the display. Enter the new target for the records to repeat the copy operation as many times as you need. To cancel the command, type over it or press F5 (Refresh).

Use the following line commands to repeatedly copy the same records:

Command	Description
CR	Copy this record to the targets specified by A, B, O, or OO, and retain this command.
CRn	Copy <i>n</i> records, starting with this record, to the targets specified by A, B, O, or OO, and retain this command.
CCR	Copy this block of records (defined by a pair of CCR commands) to the targets specified by A, B, O, or OO, and retain these commands.

When you use the Copy Repeat commands, keep the following in mind:

- Do not use the Copy Repeat line command in conjunction with the Copy or Move line commands. If you do, SEU issues an error message.
- Specify only one block of records to be copied. If you specify more than one block of records, SEU issues an error message.

Deleting Records

You can delete a record or a block of records from a member by using the following Delete line commands:

Command	Description
D	Delete this record.
DD	Delete this block of records (defined by a pair of DD commands).
Dn	Delete <i>n</i> records, starting with this record.

When you use the Delete command, keep the following in mind:

- To delete all the records following (and including) the record where the *Dn* line command is typed, use a large value for *n* in a *Dn* line command.
- You can process more than one Delete line command at the same time.

Inserting Blank Records

You can insert blank lines in a member to add new records. You can add one or more blank lines by using the following line commands:

Command	Description
I	Insert a blank line below this record. Each time you type data on the blank line and press Enter, SEU inserts another blank line.
In	Insert <i>n</i> blank lines below this record. When you type data on the last inserted line and press Enter, SEU inserts another blank line.

Note: Other Insert line commands are described in the sections “Displaying Format Lines” on page 44, “Creating Prompts” on page 40, and “Defining and Inserting Skeleton Lines” on page 47.

When you use the Insert commands, keep the following in mind:

- The *I* line commands are repeating commands. Each time you type data (including a blank) on the blank line of an *I* line command, or the last blank line of an *In* command, and press Enter, SEU inserts another blank line. This continues until you:
 - Press F5 (Refresh).
 - Press Enter without changing the newly inserted line.
 - Move the cursor off the line.
- If the value of *n* in an *In* line command is greater than the number of spaces below the *In* line command, SEU supplies only the number of blank lines that can fit on the display.
- If you press F19 (Left) or F20 (Right), SEU shifts the display left or right, but does not insert a new line until you press Enter.

Moving Records

You can move a record or block of records to another location in a member or to another member by using the following line commands:

Command	Description
M	Move this record to the target specified by A, B, O, or OO.
MM	Move this block of records (defined by a pair of MM commands) to the target specified by A, B, O, or OO.
Mn	Move <i>n</i> records, starting with this record, to the target specified by A, B, O, or OO.

You can type the line commands for a move operation in any order. For example, you can type the target (A, B, O, or OO) line command before or after typing the MM and MM line commands that identify the records to be moved.

Repeating Records

You can repeat a record or block of records on the display one or more times. The Repeat command is similar to the Copy command, but does not require a target command (A, B, O, or OO). The Repeat command automatically repeats the record or block of records immediately below the original record or records.

Use the following line commands to repeat a record on the display:

Command	Description
RP	Repeat this record immediately below this record.
RPn	Repeat this record immediately below this record <i>n</i> times.
RPP	Repeat a block of records (defined by a pair of RPP commands) immediately below this block.
RPPn	Repeat a block of records (defined by a pair of RPP commands) <i>n</i> times immediately below this block.

Printing Records

You can use a line command to print records during an edit session or a full-display browse session by using the following Line Print commands:

Command	Description
LP	Prints one record.
LPn	Prints the next <i>n</i> records, starting with this record.
LLP	Prints a block of records (defined by a pair of LLP commands).

When you use the Line Print command, keep the following in mind:

- Lines already selected with the Exclude command are not printed but remain in the member as a special record. The special record prints with a message stating how many records are excluded.
- Lines already selected with the Hide command are not printed in the full screen browse session.

Entering Data

SEU supports a variety of commands that make it easier to enter new data by inserting lines or prompts that can be used as templates for the new data. These commands are:

- Columns
- Prompt, Insert with Prompt
- Format, Insert with Format
- Skeleton, Insert Skeleton
- Tabs

Displaying a Columns Line

You can request a columns line on the display to make it easier to insert or edit source. The columns line numbers the columns across the display, even if you shift the display to the left or right by using the F19 (Left) and F20 (Right) keys.

Use the following line command to request SEU to show a free-format columns line:

Command	Description
COLS	Insert a columns line above this record.

Creating Prompts

You can request a prompt for any data record. A prompt separates and labels each field in a record, and is shown at the bottom of the current display. You can specify the prompt type with the Prompt command, or you can select the type by using the Select Prompt display command. For more information on using prompts and the Select Prompt display, see Chapter 9, "Editing with Prompts and Format Lines" on page 73.

Use the following line commands to place an existing record in a prompt:

Command	Description
P	Place this record in a prompt that has the same format as this record.
P?	Show the Select Prompt display to select a prompt type. Place this record in the prompt selected from that display.
Pxx	Place this record in a prompt that has specified format xx. For example, type the PCB line command to place this record in a COBOL prompt.

You can also request a prompt for a new record. SEU inserts a blank line into the member, and then places the blank line in a prompt at the bottom of the display.

Use the following line commands to insert a blank line and place it in a prompt:

Command	Description
IP	Insert a blank line after this record, and place the blank record in a prompt with the format of this record.

- IP?** Show the Select Prompt display to select a prompt type. Insert a blank line after this record, and place the blank line in the prompt selected from that display.
- IPxx** Insert a blank line after this record, and place the blank record in a prompt with the specified format *xx*. For example, type the IPCB line command to insert a blank line after this record, and to place the record in a COBOL prompt.

When you use the Prompt line commands, keep the following in mind:

- The *xx* is the 1-character or 2-character code for the prompt type.
- When you use the P line command, SEU checks positions of the record to determine its prompt type based on the source type you are using.
- When you use the P line command (or press F4) to edit CL commands of source type BND, CL, CL38, CLLE, CLP, CLP38, CMD, or CMD38, SEU requests a command prompt. The command prompt shows the values you entered on the Edit display and default values for the command.
- The prompt command is a repeating operation:
 - For the P and Pxx commands, SEU places the next record in the prompt each time you press Enter.
 - For the IP and IPxx line commands, SEU inserts another blank line for the prompt each time you press Enter. SEU stops inserting blank lines and removes the IP command if you press Enter without entering any data in the current prompt.
- SEU continues to place records in the prompt until you:
 - Reposition the Edit display so the line in the prompt is not on the display.
 - Press F5 (Refresh) or F12 (Cancel).
 - Reach the end of the member.
 - Reach the beginning of the member by using F11 (Previous record) or the TOP command.

Notes:

1. You can type line commands under the field label *Sequence number* in the prompt just as you would type line commands in the *Sequence-number* field of the records being shown.
2. You can also request a prompt by positioning the cursor on the record you want to place in a prompt, and pressing F4 (Prompt).

Using Prompts for New Records – Example

You can use the IPxx line command to insert a blank line into the member and place a blank record in a prompt with the specified format *xx*.

Type the IPC line command in sequence number 0004.00, as shown in the following display. The format code for the RPG calculation prompt is C.

Note: In this example, the line commands shown in the *Sequence number* field are followed by blanks to make them easier to read. You do not have to type the blanks.

```

Columns . . . : 6 76          Edit          LIBRNAME01/FILENAME01
SEU==>
FMT F FFilenameIPEAF....RlenLK1AI0vK1ocEDevice+.....KExit++Entry+A....U1....
***** Beginning of data *****
0001.00 F*  SAMPLE PROGRAM 5
0002.00 F*
0003.00 FCUSMINQ CF      E          WORKSTN
IPC      FCUSMSTL IF          K          DISK
***** End of data *****

```

Press Enter. The following display shows that SEU inserts a blank line into the member after sequence number 0004.00, and places a blank record in the prompt with the specified RPG calculation format.

```

Columns . . . : 6 76          Edit          LIBRNAME01/FILENAME01
SEU==>
FMT F FFilenameIPEAF....RlenLK1AI0vK1ocEDevice+.....KExit++Entry+A....U1....
***** Beginning of data *****
0001.00 F*  SAMPLE PROGRAM 5
0002.00 F*
0003.00 FCUSMINQ CF      E          WORKSTN
0004.00 FCUSMSTL IF          K          DISK
''''''''

***** End of data *****

Prompt type . . .  C      Sequence number . . .  ''''''''

Level  N01N02N03  Factor 1  Operation  Factor 2  Result
-----
Length  Decimal
        Positions  H/N/P  HI  LO  EQ  Comment
-----

F3=Exit  F4=Prompt  F5=Refresh  F11=Previous record
F12=Cancel  F23=Select prompt  F24=More keys

```

Using Prompts for Embedded SQL Statements – Example

If you use the P line command (or press F4) when you are editing an embedded SQL statement in source types CICSSQLCBL, SQLCBL, SQLCBLLE, SQLRPG, SQLRPGLE, and SQLFTN, SEU requests an SQL prompt.

For example, the following display shows an embedded SQL statement in a COBOL member.

```

Columns . . . : 1 71          Edit          LIBRNAME01/FILENAME01
SEU==>
FMT CB .....-A+++B+++++*****
***** Beginning of data *****
0001.00          MOVE A TO B.
SQL          EXEC SQL
SQL          CREATE COLLECTION ABC
SQL          END-EXEC.
0005.00          MOVE A TO B.
SQL          EXEC SQL
***** End of data *****

```

If you use the P command or press F4 (Prompt) in sequence numbers 0001.00, 0002.00, 0004.00, or 0005.00, SEU calls COBOL prompting for these lines. An IP command in sequence numbers 0001.00, 0003.00, 0004.00, or 0005.00 inserts lines with COBOL prompting being performed after that line. An IP command in sequence number 0003.00 will result in an improper SQL statement if you enter a regular COBOL statement during prompting.

If you use the P command or press F4 (Prompt) in sequence number 0003.00, SEU calls SQL prompting on that line. An IP command in sequence number 0006.00 calls SQL prompting. If a valid SQL statement is then entered in the prompt, the member is returned as shown in the following display.

```

Columns . . . : 1 71          Edit          LIBRNAME01/FILENAME01
SEU==> _____ MEMBNAME01
FMT CB .....-A+++B+++++
***** Beginning of data *****
0001.00      MOVE A TO B.
SQL          EXEC SQL
SQL          CREATE COLLECTION ABC
SQL          END-EXEC.
0005.00      MOVE A TO B.
SQL          EXEC SQL
SQL          CLOSE DEF
SQL          END-EXEC
***** End of data *****

```

If the inserted line follows an EXEC SQL line, a blank line is passed to the SQL prompter instead of performing COBOL prompting. If a new SQL statement is returned to SEU, that new statement is inserted after the EXEC SQL line and a new END-EXEC is added by SEU if one does not already exist (record 0008.00) after the inserted line. The cursor is placed in the line command area of the END-EXEC line.

Notes:

1. SQL FORTRAN does not have closing delimiters, so none will be added in SQL FORTRAN.
2. Multiple statements cannot be entered between SQL delimiters.
3. Members of type CICSSQLCBL can have embedded CICS and SQL statements in the COBOL source. The lines that contain CICS statements must begin with EXEC CICS, and end with END-EXEC.

The SQL prompting is done for SQL statements only. Statements that are CICS or AS/400 COBOL receive COBOL prompting. If an SQL statement is in a CICS statement, the SQL statement is invalid and will receive COBOL prompting.

Because SQL only allows one SQL statement between a pair of SQL delimiters, SEU will treat all data between these lines as one SQL statement and will view data returned by the SQL prompter as one SQL statement.

Because SQL prompting takes you to a new display, SEU follows the same conventions as for CL and BASIC and prompting ends after the SQL prompt is displayed.

SQL statements in host language programs are identified as follows:

- SQLCBL and CICSSQLCBL. Each SQL statement is preceded by an EXEC SQL delimiter and followed by an END-EXEC delimiter. These SQL delimiters must be the only entry on the line in which they occur or SEU will not recognize them.
- SQLFTN. Each SQL statement is preceded by an EXEC SQL delimiter. This delimiter must be the only entry on the line in which it occurs or SEU will not recognize it as a delimiter. SQL FORTRAN statements do not have closing SQL delimiters.
- SQLRPG. Each SQL statement is preceded by a C/EXEC SQL delimiter and followed by a C/END-EXEC delimiter. Each line between the SQL delimiters has a C+ in columns 6 and 7. The C/END-EXEC delimiter must be the only entry on the line in which it occurs.

Displaying Format Lines

You can insert a format line on the display to help you type or edit records in the member. A format line is shown immediately above the record you are editing or creating, and labels the fields in the record according to the source type. You can specify the source type with the Format command, or you can select the type by using the Select Format display. For more information on using format lines and the Select Format display, see “Format Lines” on page 76.

Use the following line commands to request SEU to show a format line. The format line appears above the line with the Format command.

Command	Description
F	Insert a format line above this record with the same format as the record.
F?	Show the Select Format display. Insert a format line above this record with the format type selected from that display.
Fxx	Insert a format line above this record that has the specified format xx. For example, type the FCB line command to insert a COBOL format line above this record.

You can also request SEU to insert a format line followed by one or more blank lines for new records.

Use the following Insert-with-Format commands to insert a format line and one or more blank lines. The format line and blank lines are inserted after the line with the Insert-with-Format command.

Command	Description
IF	Insert a format line and one blank line below this record. The format line has the format of this record. Each time you type data on the blank line and press Enter, SEU inserts another blank line.
IFn	Insert a format line and <i>n</i> blank lines below this record. The format line has the format of this record.
IF?	Show the Select Format display to select a specific format. Insert a format line below this record with the format selected from that display. Insert a blank line below the format line.

- IFxx** Insert a format line and one blank line below this record. The format line has the specified format xx. Each time you type data on the blank line and press Enter, SEU inserts another blank line. For example, type the IFCB line command to insert a COBOL format line, and a blank record below it.
- IFxxn** Insert a format line and *n* blank lines below this record. The format line has the specified format xx.

When you use the Format or Insert-with-Format line commands, keep the following in mind:

- The code xx is a 1-character or 2-character format identifier of the format to be displayed. When you do not specify a format identifier, SEU examines the record and determines the format based on the source type you are using.
- The format lines are only temporary records and are not part of the source member. Use the D line command or press F5 (Refresh) to delete them while in the edit session. SEU ignores remaining format lines when it saves the changed member. (A Dn command will do the same as a D command when specified on a format line.)
- The third line of the Edit display is an automatic format line. SEU automatically shows this format line based on the member source type and the type of the first data record below it.
- The IF and IFxx line commands are repeating commands. Each time you type data on the blank line and press Enter, SEU inserts a blank line. This continues until you end the edit session, press F5 (Refresh), or move the cursor off the insert line and press any key.

Inserting a Format Line – Example

In the C program segment shown in the following display, type the F line command in sequence number 0023.00.

Note: In this example, the line commands shown in the *Sequence number* field are followed by blanks to make them easier to read. You do not have to type the blanks.

```

Columns . . . : 1 71          Edit          LIBRNAME01/FILENAME01
SEU==>                                     MEMBNAME01
FMT C .....CL0N01N02N03Factor1+++OpcodeFactor2+++ResultLenDHHiLoEqComments++++
0014.00 H*****
0015.00 FCUSMSTL IF E          K          DISK
0016.00 FORDFILL UF E          K          DISK
0017.00 6FRD400D 12 E          WORKSTN
0018.00 F          G  SSSSSSSSS          SFNUM KSFIL SFDATA
0019.00 C          START TAG
0020.00 C          ' ' POST          DSPSTT
0021.00 C          'B18' POST          DSPSTT
0022.00
F          C          'B12' POST          DSPSTT
0024.00 C          RETRN
0025.00 C          EXFMTEVOKE
***** End of data *****

```

Press Enter. SEU determines that the source type of record 0023.00 is C and inserts the FMT C format line above record 0023.00, as shown in the following display.

```

Columns . . . : 1 71          Edit          LIBRNAME01/FILENAME01
SEU==>          MEMBNAME01
FMT C .....CL0N01N02N03Factor1+++OpcdeFactor2+++ResultLenDHHiLoEqComments++++
0014.00        H*****
0015.00        FCUSMSTL IF E          K          DISK
0016.00        FORDFILL UF E          K          DISK
0017.00        6FRD400D 12 E          WORKSTN
0018.00        F          G  SSSSSSSSS          SFNUM KSFIL SFDATA
0019.00        C          START TAG
0020.00        C          ' ' POST          DSPSTT
0021.00        C          'B18' POST          DSPSTT
0022.00
FMT C .....CL0N01N02N03Factor1+++OpcdeFactor2+++ResultLenDHHiLoEqComments++++
0023.00        C          'B12' POST          DSPSTT
0024.00        C          RETRN
0025.00        C          EXFMTEVOKE
***** End of data *****

```

The format line lists the abbreviated titles of the fields. Use the format line to check that values are in the correct positions or to help you add or change values in the record.

Inserting Blank Lines with a Format Line – Example

Type the IFF2 line command in sequence number 0016.00 to request two blank lines under an F format line, as shown in the following display.

Note: In this example, the line commands shown in the *Sequence number* field are followed by blanks to make them easier to read. You do not have to type the blanks.

```

Columns . . . : 1 71          Edit          LIBRNAME01/FILENAME01
SEU==>          MEMBNAME01
FMT C .....CL0N01N02N03Factor1+++OpcdeFactor2+++ResultLenDHHiLoEqComments++++
0014.00        H*****
0015.00        FCUSMSTL IF E          K          DISK
IFF2          FORDFILL UF E          K          DISK
0017.00        6FRD400D 12 E          WORKSTN
0018.00        F          G  SSSSSSSSS          SFNUM KSFIL SFDATA
0019.00        C          START TAG
0020.00        C          ' ' POST          DSPSTT
0021.00        C          'B18' POST          DSPSTT
0022.00
FMT C .....CL0N01N02N03Factor1+++OpcdeFactor2+++ResultLenDHHiLoEqComments++++
0023.00        C          'B12' POST          DSPSTT
0024.00        C          RETRN
0025.00        C          EXFMTEVOKE
***** End of data *****

```

Press Enter. SEU inserts the F format line followed by two blank lines, as shown in the following display.

```

Columns . . . . : 1 71          Edit          LIBRNAME01/FILENAME01
SEU==>          MEMBNAME01
FMT C  ....CL0N01N02N03Factor1+++OpcdeFactor2+++ResultLenDHHiLoEqComments++++
0014.00 H*****
0015.00 FCUSMSTL IF E          K          DISK
0016.00 FORDFILL UF E          K          DISK
FMT F  ....FFilenameIPEAF....RlenLK1AI0vK1ocEDevice+.....KExit++Entry+A....U
.....
.....
0017.00 6FRD400D 12 E          WORKSTN
0018.00 F          G  SSSSSSSSS          SFNUM KSFIL SFDATA
0019.00 C          START TAG
0020.00 C          ' ' POST          DSPSTT
0021.00 C          'B18' POST          DSPSTT
0022.00
FMT C  ....CL0N01N02N03Factor1+++OpcdeFactor2+++ResultLenDHHiLoEqComments++++
0023.00 C          'B12' POST          DSPSTT
0024.00 C          RETRN

```

Defining and Inserting Skeleton Lines

You can define a line of data you type repeatedly as a skeleton line. Once the line is defined as a skeleton line, it can be inserted into the member as needed. You can keep the same data or use the line as a template to enter new data.

Use the following line commands to create and insert skeleton lines:

Command	Description
S	Define the contents of this line as the skeleton line.
IS	Insert the current skeleton line below this record.
ISn	Insert the current skeleton line <i>n</i> times below this line.

When you use the Skeleton line command, keep the following in mind:

- After you have selected a line as the skeleton line, SEU keeps it as the skeleton line until you specify another line.
- You must type data (or a blank) on an inserted skeleton line and press Enter to make it part of the member.
- If you type the S line command in a sequence number and then move the cursor to any column position of the record in the same line before you press Enter, SEU remembers the cursor position in the record for all subsequent Insert Skeleton commands with that skeleton line.
- If the sequence number area already contains the characters SQL or SOSI, you must type the S line command in the first column and follow it with at least one blank.

Displaying Tabs

You can show a line on the display that indicates the current tab settings by using the following line command:

Command	Description
TABS	Set and show the tabs for the display.

When you use the Tabs command, keep the following in mind:

- To set tabs, type any characters in the columns where you want them. SEU converts each character to a dash (–) when it creates the tabs line.
- SEU does not create tabs for two consecutive columns.
- You must specify Y (Yes) for the *Tabs on* prompt on the Change Session Defaults display to use the tabs you set. After you have set the tabs, they remain on the Edit display until you clear them, reset them, or turn them off, even if you exit from SEU.
- To clear tabs, blank out the characters (–) indicating their positions, and press Enter.
- To set new tabs, type characters in the new positions.
- To temporarily turn the tabs off, specify N (No) for the *Tabs on* prompt on the Change Session Defaults display.

Note: You can type SET TABS ON or SET TABS OFF on the SEU command line instead of using the Change Session Defaults display. See “SET Command” on page 67 for more details.

- To move the cursor from one tab position to the next tab position, press Enter.
- To remove the tabs line from the display, press F5 (Refresh) or use the D line command. To show the tabs line again, type TABS and press a positional function key.

Inserting a Tabs Line – Example

Type the TABS command in sequence number 0016.00, as shown in the following display.

Note: In this example, the line commands shown in the *Sequence number* field are followed by blanks to make them easier to read. You do not have to type the blanks.

```
Columns . . . : 1 71          Edit          LIBRNAME01/FILENAME01
SEU==> _____ MEMBNAME01
FMT **  ...+... 1 ...+... 2 ...+... 3 ...+... 4 ...+... 5 ...+... 6 ...+... 7
0014.00 This is a record
0015.00 This is a record
TABS   This is a record
0017.00 This is a record
0018.00 This is a record
0019.00 This is a record
***** End of data *****
```

Press Enter. SEU displays a blank tabs line, as shown in the following display.

```

Columns . . . : 1 71          Edit          LIBRNAME01/FILENAME01
SEU==>          MEMBNAME01
FMT **  ...+... 1 ...+... 2 ...+... 3 ...+... 4 ...+... 5 ...+... 6 ...+... 7
0014.00 This is a record
0015.00 This is a record
TABS
0016.00 This is a record
0017.00 This is a record
0018.00 This is a record
0019.00 This is a record
***** End of data *****

```

Type a character for each tab setting you want on the tabs line, as shown in the following display. You can type any character or combination of characters.

```

Columns . . . : 1 71          Edit          LIBRNAME01/FILENAME01
SEU==>          MEMBNAME01
FMT **  ...+... 1 ...+... 2 ...+... 3 ...+... 4 ...+... 5 ...+... 6 ...+... 7
0014.00 This is a record
0015.00 This is a record
TABS          $$$      &      *      6
0016.00 This is a record
0017.00 This is a record
0018.00 This is a record
0019.00 This is a record
***** End of data *****

```

Press Enter. SEU replaces each character you typed with a dash (-) to create a tabs line, as shown in the following display.

```

Columns . . . : 1 71          Edit          LIBRNAME01/FILENAME01
SEU==>          MEMBNAME01
FMT **  ...+... 1 ...+... 2 ...+... 3 ...+... 4 ...+... 5 ...+... 6 ...+... 7
0014.00 This is a record
0015.00 This is a record
TABS          - -      -      -      -
0016.00 This is a record
0017.00 This is a record
0018.00 This is a record
0019.00 This is a record
***** End of data *****

```

In this example, you typed tabs in columns 10, 11, and 12. Because SEU does not set tabs for consecutive columns, SEU sets tabs only for columns 10 and 12. These tab settings remain in effect until you reset them or turn them off by using the SET TABS OFF command or by using the Change Session Defaults display. Press Enter to move from one tab position to the next.

Changing the Display

You can change which records or which part of the records you see on the display by using the following line commands:

- Absolute position
- Exclude
- Show
- Shift

- Shift-with-truncate
- Relative position
- Window

Positioning Records on the Display

You can reposition the records in the member to show the section you want to edit or browse. Use the following line commands to cause the next display to begin with the specified record:

Command	Description
<i>n</i>	Position record <i>n.00</i> as the first record on the display.
<i>.n</i>	Position record <i>0.n</i> as the first record on the display.
<i>n.n</i>	Position record <i>n.n</i> as the first record on the display.

If the member does not contain a record with the exact sequence number you specify, SEU positions the record with the next smallest sequence number as the first record on the display. If no record has a lower sequence number, SEU shows the beginning of the member, with the beginning-of-data record positioned as the first record on the display.

Notes:

1. If a blank appears in an Absolute Positioning command, SEU uses only the numbers to the left of the first blank to reposition the display.
2. Absolute Positioning commands cannot be entered in a sequence number that contains another type of line command.
3. When you use an Absolute Positioning command to position a record, you must press Field Exit to clear the remaining digits or insert a blank following the command. If you do not do this, all the digits following the command are interpreted as part of the positioning number.

Excluding Records from the Display

You can exclude one or more records from appearing on the display with the Exclude command. The selected records are not shown on the display, but remain in the member. A special record appears with a message stating how many records are excluded from the display.

Use the following line commands to exclude records from the display:

Command	Description
X	Excludes this record from the display.
Xn	Excludes this and the next <i>n</i> records from the display.
XX	Excludes this block of records (defined by a pair of XX commands) from the display.

When you use the Exclude command, keep the following in mind:

- You can use the Exclude line command with the Find/Change Options display to search only parts of a member.
- Press F5 (Refresh) to show all excluded records. This will also show all hidden records.

- Line commands consider a group of excluded records as one record.
- Syntax checking is not affected by the Exclude line command. If you specify a range of lines on the Change Session Defaults display, all lines in the range are checked, including any lines you excluded. If any of the excluded lines have errors, SEU includes the lines again and lists the errors.

Excluding Records – Example

Type the X4 line command in the sequence number. Press Enter. SEU excludes the records and inserts the data-records-excluded special record, as shown in the following display:

```

Columns . . . :   1 71           Edit           LIBRNAME01/FILENAME01
SEU==>                               MEMBNAME01
FMT **  ...+... 1 ...+... 2 ...+... 3 ...+... 4 ...+... 5 ...+... 6 ...+... 7
0012.00 This is a record
----- 4 data records excluded -----
0017.00 This is a record
0018.00 This is a record
0019.00 This is a record
***** End of data *****

```

Showing Excluded Records

To display records that you previously excluded by using the EXCLUDE command or hid by using the HIDE command, use the following Show commands:

Command	Description
SF	Shows the first record in the group of excluded or hidden records.
SFn	Shows the first n records in the group of excluded or hidden records.
SL	Shows the last record in the group of excluded or hidden records.
SLn	Shows the last n records in the group of excluded or hidden records.

Note: You must type the Show line commands on special records.

For information on using the HIDE command, see “HIDE Command” on page 63.

Showing Excluded Records – Example

Assume that four records are excluded from the display. Type the SF2 command on the data-records-excluded line, and press Enter. SEU shows the first two excluded records, as shown in the following display.

```

Columns . . . : 1 71          Edit          LIBRNAME01/FILENAME01
SEU==>                                     MEMBNAME01
FMT **  ...+... 1 ...+... 2 ...+... 3 ...+... 4 ...+... 5 ...+... 6 ...+... 7
0012.00 This is a record
0013.00 This is the first record to be excluded
0014.00 This is the second record to be excluded
- - - - - 2 data records excluded - - - - -
0017.00 This is a record
0018.00 This is a record
0019.00 This is a record
***** End of data *****

```

To show all excluded records, press F5 (Refresh).

Rolling the Member Forward or Backward

You can roll the member to edit or browse another portion of the member by using the following line commands:

Command	Description
+	Roll the member forward one line on the display.
+ <i>n</i>	Roll the member forward <i>n</i> lines on the display.
-	Roll the member backward one line on the display.
- <i>n</i>	Roll the member backward <i>n</i> lines on the display.

You can also use the Page Up and Page Down keys to position the records.

Shifting the Data in Records

You can shift the data in a record or block of records right or left. Use the Shift command if you want to shift the data but do not want to truncate it.

Use the following line commands to shift data without truncating it:

Command	Description
L	Shift the data in this record left one position.
L<i>n</i>	Shift the data in this record left <i>n</i> positions.
LL	Shift the data in this block of records (defined by a pair of LL commands) left one position.
LL<i>n</i>	Shift the data in this block of records (defined by a pair of LL commands) left <i>n</i> positions.
R	Shift the data in this record right one position.
R<i>n</i>	Shift the data in this record right <i>n</i> positions.
RR	Shift the data in this block of records (defined by a pair of RR commands) right one position.
RR<i>n</i>	Shift the data in this block of records (defined by a pair of RR commands) right <i>n</i> positions.

When you use the Shift line command, keep the following in mind:

- If you request a shift value that would shift data off the end of the record, SEU shifts the data as far as possible and places the word **SHIFT** in the *Sequence-number* prompt of the record or records that it could not completely shift.
- For a block shift, you can type the *n* on either block command.

Shifting a Block of Records – Example

Type the RR line command in the sequence number area to indicate the beginning of the block. Type the RR5 line command in the sequence number area of a following record to indicate both the end of the block, and that you want the data to be shifted 5 positions to the right. Press Enter. SEU shifts the block of records, as shown in the following display:

```

Columns . . . : 1 71          Edit          LIBRNAME01/FILENAME01
SEU==>                                     MEMBNAME01
FMT **  ..... 1 ..... 2 ..... 3 ..... 4 ..... 5 ..... 6 ..... 7
0025.00          This is record number 25
0026.00          This record has the first RR command
0027.00          This is record number 27
0028.00          This is record number 28
0029.00          This record has the second RR command
0030.00          This is record number 30
***** End of data *****

```

Shifting and Truncating the Data in Records

You can shift data right or left in the records and allow data to be truncated if necessary. Use the following Shift-with-Truncate line commands to perform these operations:

Command	Description
LT	Shift the data in this record one position to the left, possibly losing data off the beginning of the record.
LTn	Shift the data in this record n positions to the left, possibly losing data off the beginning of the record.
LLT	Shift the data in the block of records (defined by a pair of LLT commands) one position to the left, possibly losing data off the beginning of the record.
LLTn	Shift the data in the block of records (defined by a pair of LLT commands) n positions to the left, possibly losing data off the beginning of the record.
RT	Shift the data in this record one position to the right, possibly losing data off the end of the record.
RTn	Shift the data in this record n positions to the right, possibly losing data off the end of the record.
RRT	Shift the data in the block of records (defined by a pair of RRT commands) one position to the right, possibly losing data off the end of the record.

RRTn Shift the data in the block of records (defined by a pair of RRT commands) *n* positions to the right, possibly losing data off the end of the record.

A pair of block commands must have matching suffixes. If the suffixes do not match, SEU issues an error message. The following examples illustrate correct and incorrect block commands:

Valid	Valid	Valid	Valid	Invalid
LL01.00	LL66	LL01.00	LL23	LL66
0002.00	0002.00	0002.00	0002.00	0002.00
0003.00	0003.00	0003.00	0003.00	0003.00
0004.00	0004.00	0004.00	0004.00	0004.00
LL05.00	LL05.00	LL34	LL23	LL34

Controlling the Window Position

You can control the horizontal position of the data on the display, allowing you to view different sections of a record. Use the following Window line commands to perform this operation:

Command	Description
W	Show data position 1 of the records as the first position of the display.
Wn	Show data position <i>n</i> of the records as the first position of the display.

In addition to the Window line commands, you can also press F19 (Left) and F20 (Right) to move the display horizontally.

If you specify an *n* that is larger than the total number of positions in your record, SEU shows the last position in the record, which includes the date.

Changing the Horizontal Position – Example

Type the W6 line command in the sequence number area, and press Enter. SEU repositions the display so that data in column 6 appears as the first position, as shown in the following display:

```

Columns . . . : 6 76          Edit          LIBRNAME01/FILENAME01
SEU==> _____ MEMBNAME01
FMT ** ... 1 ...+... 2 ...+... 3 ...+... 4 ...+... 5 ...+... 6 ...+... 7 ... + .
0022.00 67890000000000200000000030000000004000000000500000000060000000007
0023.00 67890000000000200000000030000000004000000000500000000060000000007
0024.00 67890000000000200000000030000000004000000000500000000060000000007
***** End of data *****

```

Rules for Entering Line Commands

Follow these rules when entering line commands:

- Type the line command anywhere in the *Sequence-number* prompt.
If the sequence number area does not contain a sequence number, however, type the line command starting in the first position of the sequence number area followed by a blank.
- Type suffixes (numbers or format identifiers) immediately after the command. Do not type a blank between the code and the suffix. For example, type D3 (not D $\text{b}3$) or FP (not F $\text{b}P$).
- Use only the following line commands on a format or tabs line: D, *Wn*, *+n*, *-n*, and *n*.
- Use only the following line commands on the beginning-of-data display line: A, *An*, *Wn*, *+n*, *-n*, *n*, I, *ln*, IP, *IPxx*, IF, *IFn*, *IFxx*, *IFxxn*, IS, and *ISn*.
- Use only the following line commands on the end-of-data display line: B, *Bn*, *Wn*, *+n*, *-n*, and *n*.

SEU issues an error message if you enter an invalid line command. To continue processing, you must correct the error, type over it to blank it out, or press F5 (Refresh).

For a list of the valid line commands for each display, see “Summary of Line Commands” on page 59.

Performing More Than One Operation

You can perform more than one operation at the same time if the line commands you type do not conflict. For example, you can type a Delete (D) line command, a Block Move (MM MM) and Before (B) target line commands, and a Relative Position (*+n*) line command on the same display. SEU performs all three operations when you press any positional function key such as Enter, Page Up, Page Down, F19 (Left), or F20 (Right).

Overlapping Commands

Overlapping occurs when two or more line commands affect the same line on the display. Most line commands cannot overlap. You can, however, overlap the following line commands:

Window	W, <i>Wn</i>
Columns	COLS
Tabs	TABS
Skeleton	S, IS, <i>ISn</i>
Format	F, F?, <i>Fxx</i>
Relative Positioning	+, <i>+n</i> , -, <i>-n</i>

Pending Operations

An operation is called *pending* when only some of the necessary line commands have been entered. For example, the Block Move operation requires two MM line commands to define the block of records to be moved and a target line command (A, B, or O). The Block Move operation is pending if you enter only the first MM line command and a target line command, or two MM line commands and no target line command.

The first pending operation appears in the *Pending status message* prompt in the upper right corner of the Edit display.

To cancel a pending operation, blank out or type over the current line command in the *Sequence-number* prompt.

To cancel all pending operations, press F5 (Refresh).

Using Line Commands during Pending Operations

You can specify new line commands while previous line commands are pending completion.

When using line commands during pending operations, keep the following in mind:

- Conflicting line commands must be resolved before you can continue with a pending operation.
- Conflicting line commands must be resolved before SEU can process any other line commands on the display.
- Line commands are processed in a top-down order on the edit display. Line commands that require a target command (Copy, Move, Copy Repeat) must not be separated from the target command by another line command that requires a target command.
- Some line commands cannot overlap. For more information on overlapping line commands, see “Overlapping Commands” on page 55.

Line Command during Pending Operation – Example

To see an example of how conflicting line commands work with a pending operation, do the following:

1. Type the line commands on the Edit display as shown in the following example, and press Enter.

Note: In this example, the line commands shown in the *Sequence number* field are followed by blanks to make them easier to read. You do not have to type the blanks.

```

Columns . . . : 1 71          Edit          LIBRNAME01/FILENAME01
SEU==>          MEMBNAME01
FMT **  ...+... 1 ...+... 2 ...+... 3 ...+... 4 ...+... 5 ...+... 6 ...+... 7
***** Beginning of data *****
0001.00 Line 1
C      Line 2
0003.00 Line 3
0004.00 Line 4
C      Line 5
A      Line 6
0007.00 Line 7
0008.00 Line 8
0009.00 Line 9
M      Line 10
0011.00 Line 11
0012.00 Line 12

```

No line commands are processed and the following error message appears at the bottom of the display:

Command conflict.

The command conflict in this example is that the Copy (C) command in sequence number 002.00 and the Copy (C) command in sequence number 0005.00 are two line commands that require a target command. The After (A) target command follows the C command in sequence number 0005.00. No target command follows the C command in sequence number 0002.00.

2. To resolve the conflict, type the After (A) command in sequence number 0003.00, and press Enter. The command conflict is resolved. SEU processes the line commands in a top-down order by:
 - a. Matching the Copy (C) command in sequence number 0002.00 with the After (A) target command in sequence number 0003.00.
 - b. Matching the Copy (C) command in sequence number 0005.00 with the After (A) command in sequence number 0006.00.
 - c. Showing the Move (M) command in sequence number 0010.00 as a pending operation.

Using Line Commands on Split Displays

You can use a split Edit/Browse display to copy records from one member into another member. If you use the Copy (C), Multiple Copy (Cn), or Block Copy (CC) line command to perform this operation, you must specify exactly one target and the target must be in the edit session. If you use the Multiple Copy Repeated (CRn) or the Block Copy Repeated (CCR) line command, you must specify at least one target in the edit session.

The Columns (COLS) and Format (F) line commands function differently in a bottom browse session on either split display than they do on the Browse display. The initial bottom browse session of a split display does not contain a format line. When you enter an F or COLS line command, the format or columns line is shown on the third line of the bottom session. Each format line command you request replaces the previous format, so that only one format line is shown at any time.

Identifying Line Commands

When a sequence number has been altered and contains a character other than a digit (0 through 9), period, or blank, SEU identifies the contents of the field according to the following rules. (For these examples, the original sequence number is 0123.45, and b is a blank.)

- Leading digits, periods, and blanks are ignored. For example, if you change the sequence number to 012C.45, SEU recognizes the C line command. If you change the sequence number to 99bCC45, SEU recognizes the CC line command.
- The last blank or last changed digit ends the line command. For example, if you change the sequence number to C123b4, SEU recognizes the C123 line command. If you change the sequence number to C124, SEU recognizes the C124 line command. If you change the sequence number to C1b3, SEU recognizes it as the C1 line command.

Note: If the sequence number area does not contain a sequence number, enter line commands in the first column of the sequence number area followed by at least one blank to ensure the command will be processed.

When a sequence number has been altered and contains only digits (0 through 9), periods, or blanks, SEU interprets the sequence number as an Absolute Position command. The following rules apply to this type of altered sequence number. (For these examples, the original sequence number is 0123.45, and b is a blank.)

- No line command is recognized if:
 - The first character is a blank. For example, the sequence number b555b45 is not recognized as a line command, and the sequence number is reset to its original value.
 - The only change you make is to replace digits with blanks. For example, the sequence number 0b2b.b5 is not recognized as a line command, and the sequence number is reset to its original value.
- Only two digits are allowed after the decimal place. For example, sequence number 77.8888 is not a valid line command.
- The last blank or changed character ends the command. For example, if you change the sequence number to 013b.45, SEU recognizes the Absolute Positioning line command 13. If you change the sequence number to 2.2b.45, SEU recognizes the Absolute Positioning line command 2.2. If you change the sequence number to 9b3b.45, SEU recognizes the Absolute Positioning line command 9.

Summary of Line Commands

The following table lists the line commands for SEU. All line commands are valid for full edit and split edit sessions. This table indicates the line commands that are valid for browse sessions.

Command	Browse Display	Line Commands
Absolute Positioning	Y	<i>n .n n.n</i>
After, Before	N	A <i>An</i> B <i>Bn</i>
Columns	Y	COLS
Copy	Y/N ¹	C <i>Cn</i> CC
Copy Repeat	Y/N ¹	CR <i>CRn</i> CCR
Delete	Y/N ²	D <i>Dn</i> DD
Exclude	Y	X <i>Xn</i> XX
Format	Y	F <i>F?</i> <i>Fxx</i>
Insert	N	I <i>In</i>
Insert-with-Format	N	IF <i>IFn</i> <i>IF?</i> <i>IF?n</i> <i>IFxx</i> <i>IFxxn</i>
Insert-with-Prompt	N	IP <i>IP?</i> <i>IPxx</i>
Line Print	Y	LP <i>LPn</i> LLP
Move	N	M <i>Mn</i> MM
Overlay	N	O <i>On</i> OO
Prompt	N	P <i>P?</i> <i>Pxx</i>
Relative Positioning	Y	+ <i>+n</i> - <i>-n</i>
Repeat	N	RP <i>RPn</i> RPP <i>RPPn</i>
Shift Left	N	L <i>Ln</i> LL <i>LLn</i>
Shift Right	N	R <i>Rn</i> RR <i>RRn</i>
Shift-Left-with-Truncate	N	LT <i>LTn</i> LLT <i>LLTn</i>
Shift-Right-with-Truncate	N	RT <i>RTn</i> RRT <i>RRTn</i>
Show	Y	SF <i>SFn</i> SL <i>SLn</i>
Skeleton	N	S IS <i>ISn</i>
Tabs	N	TABS
Window	Y	W <i>Wn</i>

Notes:

¹ Valid only in split edit/browse sessions with a target command in the edit session.

² Valid only on special records (for example, format lines).

Chapter 8. Using Source Entry Utility Commands

You can use SEU commands to perform find/change operations, to exit from your session, and to tailor your session defaults. The commands provide a fast path for these operations, which can also be accessed through options displays. Values entered through SEU commands appear on these options displays.

You type SEU commands on the SEU command line. You can retrieve previous commands entered in the SEU command line by pressing F9 (Retrieve). You can move your cursor from the data area to the SEU command line and back to the data area by pressing F10 (Cursor).

You can use SEU commands to:

- Find records that contain a specific character string using the FIND command
- Hide records that contain a specific character string using the HIDE command
- Find and change character strings using the CHANGE command
- Tailor your edit session and tailor the find and change functions using the SET command
- Reposition the display using the TOP command and the BOTTOM command
- Save, file, or cancel changes to a member using the SAVE, FILE, and CANCEL commands

Entering SEU Commands on a Split Display

Each split display contains one command line for each session. You can enter SEU commands in the sessions that currently support equivalent function. Commands for split displays can be one of two types:

Session-dependent commands

Perform their function only in one session. If a session-dependent command is entered on the top session, it affects only the top session. If it is entered on the bottom session, it affects only the bottom session.

For example, if the FIND command is entered in the top SEU command line, SEU searches only the top session for the string.

Session-independent commands

Perform their function in both sessions, regardless of which session contains the cursor.

For example, if the SET ROLL command is entered in either session of a split display, the amount to roll for both sessions is affected.

When you use either a session-dependent command or a session-independent command, the following additional processing occurs in both sessions:

- Lines in the edit session that have been changed are updated and checked for syntax errors.
- All line commands are run before an SEU command is processed. For example, if you enter a FIND command, SEU processes all unprocessed line commands before finding the string in the appropriate session.

The following table shows the commands for each type of session on split displays. A Y indicates that the command is valid in that type of session. A Y is also used to indicate session-dependent commands. For example, the FIND command is session dependent: it finds only strings in the session containing the cursor.

Command	Function	Edit Session	Browse Session	Session-Dependent
FIND or F	Find a string of characters in a member.	Y	Y	Y
HIDE or H	Hide records that contain a specified string from the display.	Y	Y	Y
CHANGE or C	Find a string of characters in a member and change it to another string.	Y	N	Y
SET or S MATCH	Match the string of a member during the find operation.	Y	Y	Y
SET or S SHIFT	Shift data over when replacing a string during the change operation.	Y	N	Y
SET or S CAPS	Set the type of data input to uppercase or mixed case.	Y	Y	N
SET or S TABS	Use predefined tab positions.	Y	N	Y
SET or S ROLL	Set the amount the display moves up, down, left, and right.	Y	Y	N
SET or S EXPERT	Set the display to full screen mode.	Y	Y	N
TOP or T	Reposition the work screen to the first page of data.	Y	Y	Y
BOTTOM or BOT or B	Reposition the work screen to the last page of data.	Y	Y	Y
CANCEL or CAN	Cancel the session and exit or remove the bottom split browse session. CANCEL in the top session exits both sessions.	Y	Y	Y
SAVE	Save changes made to the member and continue editing.	Y	N	Y
FILE	Save changes made to the member and exit.	Y	N	Y

HIDE Command

Hides records that contain a particular character string. The short form for the HIDE command is H.

The HIDE command is session dependent on split displays. For example, if you enter the HIDE command on the command line of the top session, only the member in the top session is affected.

The HIDE command in the bottom session of a split display can hide up to 100 blocks of records only. A HIDE request beyond this limit is ignored.

In an Edit session, a special record is displayed with a message that states the number of records that are hidden from the display. In a Browse session, the special record is not displayed; however, a message is displayed once to show the number of hidden records.

You cannot use the HIDE command in a session in which:

- A line command is pending
- Line command errors are present
- A Copy Repeat command is in the sequence number area

To show hidden records, use the Show line commands, as described in “Showing Excluded Records” on page 51.

Command Syntax

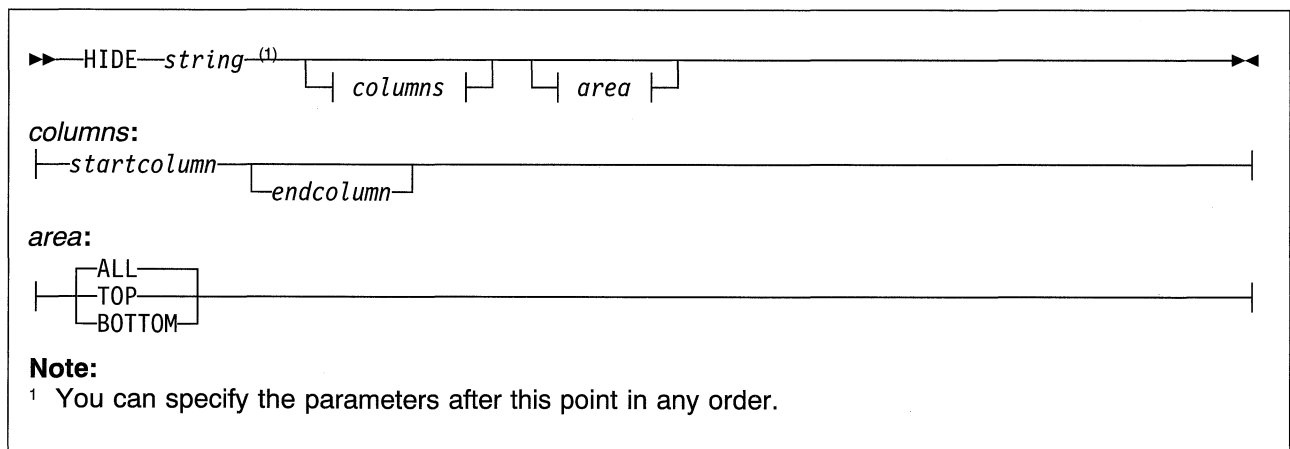

string

The character string that you want to hide. If the string includes leading, embedded, or trailing blanks, apostrophes, or quotation marks, enclose the string in apostrophes or quotation marks.

columns

The column range in which you want to search. Type a number for the starting column and another number for the ending column, separated by a blank. If you type

only one number, it is assumed to be the starting column.

If you do not specify the *columns* parameter, all columns are searched.

area

The area of the member in which records are hidden. The possible values are:

ALL or **A**

Hides all the records that contain the string.

TOP or T

Hides all the records that contain the string from the line where the cursor is positioned to the top of the member.

BOTTOM or B

Hides all the records that contain the string from the line where the cursor is positioned to the bottom of the member.

Examples: The following example hides all records in the member that contain * in column 7:

```
HIDE * 7 7 A
```

The following example hides all records from the cursor position to the top of the member that contain '*%%' in any columns:

```
H '*%%' T
```

FIND Command

Finds occurrences of a string. The short form for the FIND command is F.

The FIND command is session-dependent on split displays. For example, if you enter the FIND command on the top session, only the member in the top member is searched for the string.

After typing a FIND command on the command line, you can press F16 (Repeat find) to begin a search or to find subsequent occurrences of a string.

If you use F16 (Repeat find) to begin a search, you only have to type the string that you want to find on the command line. For example, to find the string ABCD, type ABCD on the command line and press F16. If you want to find the string CHANGE, C, FIND, or F, delimit the string with single quotation marks. For example, to find the string CHANGE, type 'CHANGE' and press F16.

Command Syntax

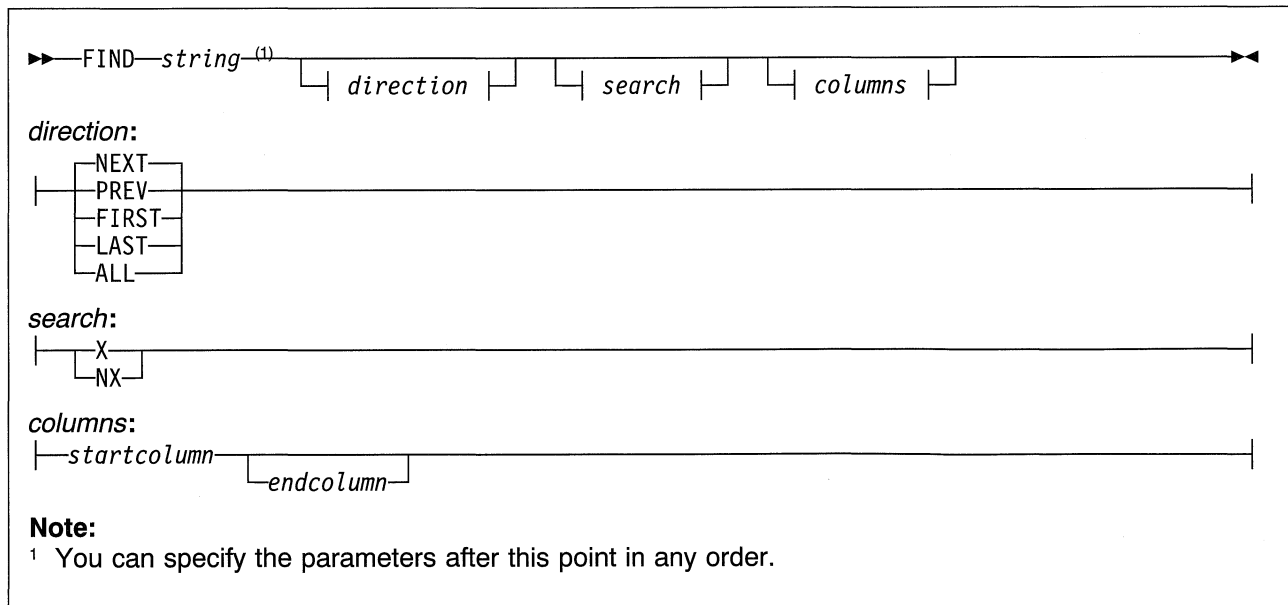
**string**

The character string you want to find. Enclose the string in quotation marks if it contains leading, imbedded, or trailing blanks,

special values, apostrophes, or quotation marks. Type an asterisk to use a string you used in the previous FIND operation. Type *ERR to find syntax errors.

direction

The direction you want to search. The possible values are:

NEXT or **N**

Finds the next occurrence of the string, starting at the position of the cursor. The find wraps to the beginning of the member when the end of the member is reached.

PREV or **P**

Finds the previous occurrence of the string, starting at the position of the cursor. The find wraps to the end of the member when the beginning of the member is reached.

After typing a FIND command with the PREV option, you must move the cursor back to the position in the data area from which you want the search to begin. To do so, press F10 (Cursor) after you type the command and then press Enter.

FIRST or **F**

Finds the first occurrence of the string.

LAST or **L**

Finds the last occurrence of the string.

ALL or **A**

Finds all occurrences of the string.

search

The lines you want to search. The possible values are:

X Searches only excluded lines.

NX

Searches only nonexcluded lines.

If you do not specify the *search* parameter, all records are searched.

columns

The column range in which you want to search.

Type a number for the starting column and another number for the ending column, separated by a blank. If you type only one number, it is assumed to be the starting column.

If you do not specify the *columns* parameter, all columns are searched.

Note: The parameters that you enter for the FIND command also appear in the corresponding prompts of the Find/Change Options display.

Examples: The following example finds the previous occurrence of the string that was previously searched for in all records and in all columns of the member:

```
F * P
```

The following example finds syntax errors in all records of the member:

```
FIND *ERR A
```

The following example finds the previous occurrence of the string `_abc` in all excluded records starting in column 15:

```
F "_abc" P X 15
```

The following example finds all occurrences of the string `'abc'` in all nonexcluded records in all columns of the member:

```
FIND "'abc'" A NX
```

CHANGE Command

Finds occurrences of a string and changes them to another string. The short form for the CHANGE command is C.

After you type a CHANGE command, you can press F16 (Repeat find) to find the first occurrence of the string without changing it. You can then press F17 (Repeat change) to change the string.

You can also press F17 (Repeat change) to both find and change a string after you type a CHANGE command.

Command Syntax

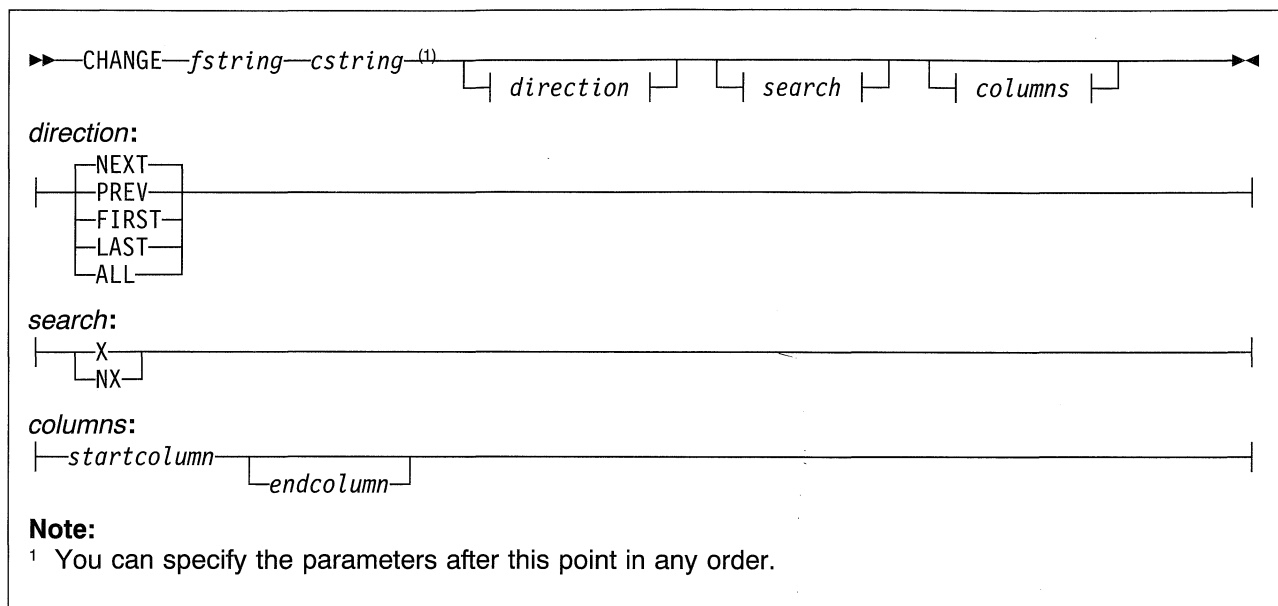

fstring

The character string you want to find. Enclose the string in quotation marks if it contains leading, imbedded, or trailing blanks, special values, apostrophes, or quotation marks. Type an asterisk to use a string you used in the previous CHANGE operation. Type *ERR to find syntax errors.

cstring

The character string that replaces the find string. Enclose the string in quotation marks if it contains leading, imbedded, or trailing blanks, special values, apostrophes, or quotation marks. Type an asterisk to use a string you used in the previous CHANGE operation.

direction

The direction you want to search. The possible values are:

NEXT or **N**

Finds the next occurrence of the string, starting at the position of the cursor. The find wraps to the beginning of the member when the end of the member is reached.

PREV or **P**

Finds the previous occurrence of the string, starting at the position of the cursor. The find wraps to the end of the member when the beginning of the member is reached.

After typing a CHANGE command with the PREV option, you must move the cursor back to the position in the data area from which you want the search to begin. To do so, press F10 (Cursor) after you type the command and then press Enter.

FIRST or **F**

Finds the first occurrence of the string.

LAST or **L**

Finds the last occurrence of the string.

ALL or **A**

Finds all occurrences of the string.

search

The lines you want to search. The possible values are:

X Searches only excluded lines.

NX

Searches only nonexcluded lines.

If you do not specify the *search* parameter, all records are searched.

columns

The column range in which you want to search.

Type a number for the starting column and another number for the ending column, separated by a blank. If you type only one

number, it is assumed to be the starting column.

If you do not specify the *columns* parameter, all columns are searched.

Note: The parameters that you enter for the CHANGE command also appear in the corresponding prompts of the Find/Change Options display.

Examples: The following example finds the next occurrence of the string `_abc`, searching all columns in all records, and changes it to `a_bc`:

```
CHANGE '_abc' 'a_bc'
```

The following example finds all occurrences of the asterisk character in all nonexcluded records starting in column 1 and ending in column 2, and changes them to the ampersand character:

```
C '*' '&' A NX 1 2
```

The following example finds the first occurrence of the string `ab'_c` in all excluded records starting in column 20, and changes it to `'abc'`:

```
C "ab'_c" "'abc'" F X 20
```

SET Command

Tailors find and change operations and session defaults. The short form for the SET command is S.

Command Syntax

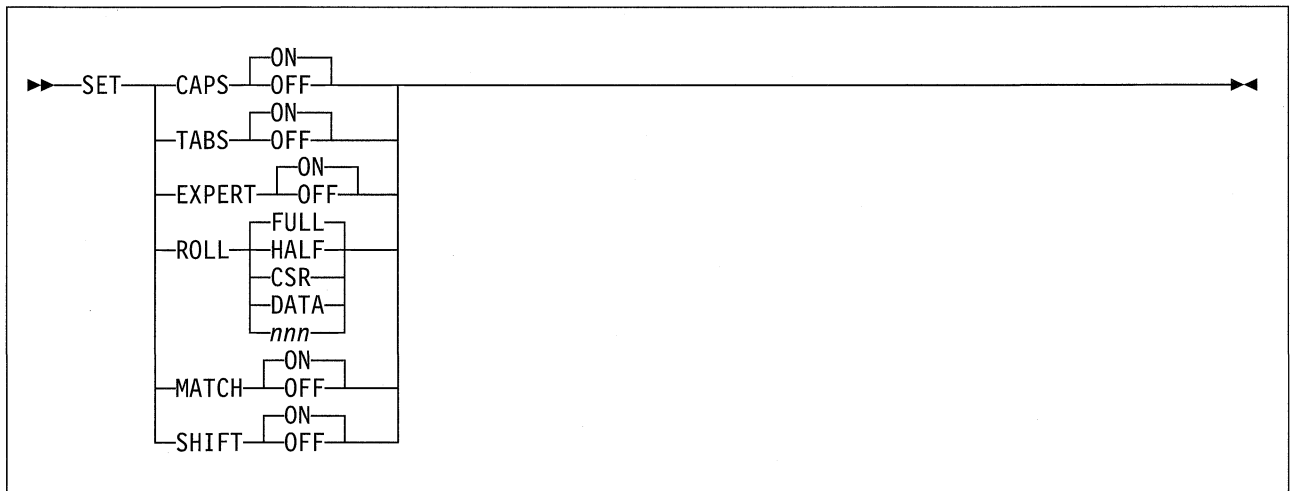

CAPS

Specifies whether the source text, find string, and change string that you enter are in uppercase only or in mixed case. The initial value depends on the source member type and your user profile. In a Browse display, the initial value is OFF.

The possible values are:

ON

Specifies uppercase.

OFF

Specifies mixed case.

TABS

Specifies whether the tabs you set with the Tabs line command are active. The initial value depends on your user profile.

The possible values are:

ON

Specifies that tabs are active.

OFF

Specifies that tabs are not active.

EXPERT

Specifies the mode of your edit or browse session. The initial value depends on your user profile.

The possible values are:

ON

Specifies normal mode.

OFF

Specifies full screen mode.

ROLL

Specifies the number of lines or columns that move on the display at one time when you press the Page Up key, Page Down key, F19 (Left), or F20 (Right). The initial value depends on your user profile.

The possible values are:

FULL or **F**

Specifies that the display moves one full display.

HALF or **H**

Specifies that the display moves one half of a display.

CSR or **C**

Specifies that the display moves by the position of the cursor.

DATA or **D**

Specifies that the display moves one full display minus one line or column.

nnn

Specifies that the display moves by 1 to 999 number of lines or columns.

MATCH

Specifies whether the case of the letters must match in a search string. The initial value is OFF.

The possible values are:

ON

Specifies that uppercase and lowercase letters must match.

OFF

Specifies that uppercase and lowercase letter do not have to match.

SHIFT

Specifies whether data is shifted when a string is replaced. The initial value depends on the source member type.

The possible values are:

ON

Specifies that data is shifted.

OFF

Specifies that data is not shifted.

Note: The parameters that you enter for the SET command (except for TABS) also appear in the corresponding prompts of the Change Session Defaults display.

TOP Command

Repositions the work screen to the first page of data, which starts on the beginning-of-data line. The short form for the TOP command is T.

Command Syntax

▶▶—TOP—▶▶

The TOP command has no parameters.

BOTTOM Command

Repositions the work screen to the last page of data, which ends on the end-of-data line. The short form for the BOTTOM command is B.

Command Syntax

```
▶—BOTTOM—◀
```

The BOTTOM command has no parameters.

SAVE Command

Saves changes to a member without exiting. You can use the SAVE command only on the Edit display and in the top command line on a split Edit/Browse display.

Command Syntax

```
▶—SAVE— [library/] [file] [member] —◀
```

library

The library in which you want to save the file that contains the member. Follow the library name with a / character. If you specify a library, you must also specify a file. The default is the current library containing the member.

file The file in which you want to save the member. If a library is specified, the file name must immediately follow the / character. The default is the current file containing the member.

member

The member in which you want to save the changed member. If a file is specified, the member name must immediately follow the file name, separated by a blank.

Notes:

1. The parameters that you enter for the SAVE command also appear in the corresponding prompts of the Exit display.
2. The System/38 terminology (FILE.LIBRARY) is not supported.
3. The parameters cannot be specified if you are editing DDS comments from SDA.

Examples: The following example saves the member RPGMEM in the file RPGSRC in the current library:

```
SAVE RPGSRC RPGMEM
```

The following example saves the member CBLMEM in the file CBLSRC in the library CBLLIB:

```
SAVE CBLLIB/CBLSRC CBLMEM
```

The following example saves the member in the current library and the current file:

```
SAVE
```

FILE Command

Saves changes to a member and exits from an edit session. You can use the FILE command only on the Edit display and in the top command line on a split Edit/Browse display. If you use the command on a split Edit/Browse display, you exit from both sessions.

Command Syntax

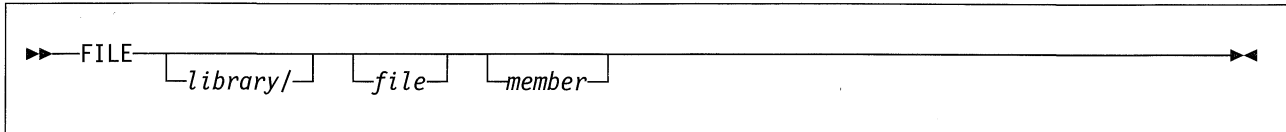

library

The library in which you want to save the file that contains the member. Follow the library name with a / character. If you specify a library, you must also specify a file. The default is the current library containing the member.

file The file in which you want to save the member. If a library is specified, the file name must immediately follow the / character. The default is the current file containing the member.

member

The member in which you want to save the changed member. If a file is specified, the member name must immediately follow the file name, separated by a blank.

Notes:

1. The parameters that you enter for the FILE command also appear in the corresponding prompts of the Exit display.
2. The System/38 terminology (FILE.LIBRARY) is not supported.
3. The parameters cannot be specified if you are editing DDS comments from SDA.

Examples: The following example saves the member RPGMEM in the file RPGSRC in the current library, and exits from the edit session:

```
FILE RPGSRC RPGMEM
```

The following example saves the member CBLMEM in the file CBLSRC in the library CBLLIB, and exits from the edit session:

```
FILE CBLLIB/CBLSRC CBLMEM
```

The following example saves the member in the current library and the current file, and exits from the edit session:

```
FILE
```

CANCEL Command

Cancels your edit or browse session and exits from it. The short form for the CANCEL command is CAN.

If you enter the CANCEL command in the top session of a split display, both sessions are canceled. If you enter it in the bottom session of a split display, only the bottom session is canceled.

If you change a member and then enter CANCEL, you are prompted to press Enter to confirm that you want to lose the changes. If you do not want to lose the changes, press F12 (Cancel) to continue editing.

Command Syntax

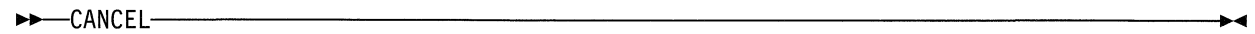
A diagram showing the command syntax for CANCEL. It consists of a horizontal line with a right-pointing arrowhead at the left end and a left-pointing arrowhead at the right end. The word "CANCEL" is positioned between these two arrowheads. The entire diagram is enclosed in a rectangular border.

▶ CANCEL ◀

The CANCEL command has no parameters.

Chapter 9. Editing with Prompts and Format Lines

Prompts and format lines help you create error-free records when you are working with members that contain fixed-format CL or HLL statements. A prompt separates and labels each field in a record, and is shown at the bottom of the Edit display. A format line is shown immediately above the record you are editing and labels the fields in the record according to the source type.

Command Prompts

You can use command prompts that are supported by the AS/400 system with SEU. When you select a command prompt, SEU calls the AS/400 system to show the command prompts.

When you request a prompt for a record, SEU passes the record to the command prompt. The command prompt determines which prompt to show. If the record is blank or an inserted line, the Major Command Group menu is shown. If the record is not blank or an inserted line, the system tries to find a prompt for the command. If a prompt for the command does not exist, SEU takes control and sends an error message from the system. For BASIC types, the BASIC Help Facility Menu is shown. For SQL types, SQL displays are shown.

For detailed information on command prompts, see the *CL Programming*, SC41-3721.

SEU does not support format lines that correspond to the command, BASIC, SQL, or user-defined prompts.

Selecting Prompts

To request a prompt, press F4 (Prompt) or F23 (Select prompt), or type the P, P?, Pxx, IP, IP?, or IPxx line command on the Edit display. Depending on the source type you are using, you obtain either a command prompt or a high-level-language prompt:

- A command prompt is displayed if you are using BND, CL38, CLLE, CLP, CLP38, CMD, or CMD38.
- An SQL prompt is displayed if you are using CICSSQLCBL, SQLCBL, SQLFTN, SQLRPG, or SQLRPGLE, and the line is valid SQL.
- Online information for BASIC is displayed if the source type of the member you are editing is BAS, BAS38, BASP, or BASP38.
- A high-level-language prompt is displayed if you are using any other source type.

Selecting a High-Level-Language Prompt

You can select the prompt used for the Edit display by using the Select Prompt display. One of four Select Prompt displays appears, depending on whether you are editing a System/36, System/38, AS/400, or ILE member type.

To access a Select Prompt display, request a prompt with the P? or IP? line command, or with F23 (Select prompt) on the Edit display. The cursor position is used to determine which record to prompt. You do not need to have a prompt showing to request the Select Prompt display. Pressing F23 does not update the fields you have changed in the prompt, but it does process line commands and updates to lines in the edit session of the display.

When you request a high-level-language prompt on an Edit display, SEU inserts the prompt in the bottom part of the display. The record remains in both the edit session and the prompt. If the prompt overlays the record, SEU repositions the display to show the record in the prompt as the first record on the display. You can type data in both the record and the prompt. When both the record and a prompt exist, data from the prompt replaces data entered in the record.

The prompt separates and labels each field in the record you selected according to the source type. Prompts make it easier to enter source information for column-oriented languages such as RPG.

You can type line commands in the *Sequence-number* field for the prompt in the same way as you type them in the *Sequence-number* field for the record. After you type the source information and press Enter, SEU makes the changes to the record from the fields in the prompt.

The following shows an example of the Edit display with a high-level-language prompt:

```

Columns . . . . : 1 71          Edit          QRPGRSRC/EDIT
SEU==>          POSTOP
FMT C . . . . .CL0N01N02N03Factor1+++OpdcFactor2+++ResultLenDHHiLoEqComments++++
0002.00         C              ' '          POST          DSPSTT
0003.00         C              'B18'       POST          DSPSTT
' ' ' ' ' ' ' '
0004.00         C              'B12'       POST          DSPSTT
0005.00         C              RE TRN
0006.00         C              EXFMTEVOKE
0007.00         C              EXFMTOUREC
0008.00         C              EXFMTEVOKE
***** End of data *****

Prompt type . . . C      Sequence number . . . ' ' ' ' ' ' ' '
Level  N01N02N03  Factor 1      Operation      Factor 2      Result
-----
          Decimal
Length  Positions  H/N/P  HI  LO  EQ  Comment
-----
F3=Exit  F4=Prompt  F5=Refresh  F11=Previous record
F12=Cancel  F23=Select prompt  F24=More keys

```

If you use prompts in full screen mode, the prompts are abbreviated.

The following display shows an example of the Edit display in full screen mode with an abbreviated high-level-language prompt.

```

Columns . . . : 1 71          Edit          QRPGRSRC/EDIT
SEU==>          POST          DSPSTT
0002.00      C          '      '          POST          DSPSTT
0003.00      C          'B18'          POST          DSPSTT
          C          'B12'          POST          DSPSTT
0004.00      C          'B12'          POST          DSPSTT
0005.00      C          RETRN
0006.00      C          EXFMTEVOKE
0007.00      C          EXFMOUTREC
0008.00      C          EXFMTEVOKE
0009.00      C          'B14'          POST          DSPSTT
0010.00      C          RETRN
0011.00      C          EXFMTEVOKE
0012.00      C          EXFMOUTREC
0013.00      C          EXFMTEVOKE
0014.00      *C
0015.00      *C

Pmt  SeqNbr  Lvl  N01N02N03  Factor1  Opcode  Factor2  Result
C          :          :          :          :          :          :          :
          Len  Dec  H/N/P  Hi  Lo  Eq  Comment
          -  -  -  -  -  -  -

```

Canceling a Prompt

If you use the IP, IPxx, or IP? line commands to insert new records with a prompt, SEU shows you a prompt to insert a record each time you press Enter. SEU continues to do so until you do one of the following:

- Press F5 (Refresh) or F12 (Cancel).
 - If you have any data entered in a prompt and you press F5 (Refresh), the data is deleted before the refresh command is run and the insert or change prompt function is canceled. In all other situations, the data is put into the member before the insert or change prompt function is canceled.
- Enter a line command or press a positional function key (Enter, Page Up, Page Down, F19, or F20) that moves the record in the prompt off the display. If the record is moved beneath the prompt, the prompt is removed but the record appears on the next display.
- Press F11 (Previous record) to place the previous record in a prompt when you are at the beginning of the member.
- Request an insert with a prompt, and then do not change any fields in the prompt. The prompt is removed and the insert record is deleted when you press Enter.
- Start a split session.

If you use the P, Pxx, or P? line commands to change existing records with a prompt, SEU places the record in a prompt each time you press Enter. SEU continues to do so until you do one of the following:

- Press F5 (Refresh) or F12 (Cancel).
- Enter a line command or press a positional function key (Enter, Page Up, Page Down, F19, or F20) that moves the record in the prompt off the display. If the record is moved beneath the prompt, the prompt is removed but the record appears with the next display.
- Press Enter to place the next record in a prompt when you are at the end of the member.
- Press F11 (Previous record) to place the previous record in a prompt when you are at the beginning of the member.
- Request a prompt, and then do not change any fields in the prompt. The prompt is removed and the insert record is deleted when you press Enter.
- Start a split session.

SEU puts the next record in a prompt in all situations except those mentioned above, and except when:

- You press F11 (Previous record)
- You press F23 (Select prompt)
- A changed record in the prompt contains a syntax error

Format Lines

Format lines are specialized scale lines that appear immediately above any lines on the Edit display. You can use format lines to find the start and end points of fields in column-oriented language statements.

SEU supports a format line for each high-level-language prompt supported. Format lines for the AS/400 source languages help you enter new source members and change existing source members.

On the Edit display, line 3 is an automatic format line that is always shown. The format line that appears is based on the source type of the member you are editing. You can also insert a format line above any record in the member, as shown in the following display.

```

Columns . . . : 1 71          Edit          QRPGSRC/EDIT
SEU==>          POSTOP
FMT C .....CL0N01N02N03Factor1+++OpcdeFactor2+++ResultLenDHHiLoEqComments++++
***** Beginning of data *****
0002.00      C          POST          DSPSTT
0003.00      C          'B18'        POST          DSPSTT
0004.00      C          'B12'        POST          DSPSTT
0005.00      C          RETRN
FMT C .....CL0N01N02N03Factor1+++OpcdeFactor2+++ResultLenDHHiLoEqComments++++
0006.00      C          EXFMTEVOKE
0007.00      C          EXFMOUTREC
0008.00      C          EXFMTEVOKE
***** End of data *****

```

To remove a format line, press F5 (Refresh) or type a D (Delete) line command in the sequence number area of the format line.

Selecting a Format Line

You can select which format line SEU uses on the display by using the Select Format display. One of four Select Format displays appears, depending on whether you are editing a System/36, System/38, AS/400, or ILE member type.

You request a format line by specifying the F, F?, Fxx, IF, IF?, or lxx line command on the Edit display.

To access a Select Format display, request a format line with the IF? or F? line command.

Chapter 10. Creating Prompts

In addition to the IBM supplied prompts, you can create your own prompts for use with SEU. The IBM supplied prompts are the AS/400 command prompts supported by SEU, and the SEU high-level-language (HLL) prompts. User-defined prompts are prompts you can create and define to fit your specific requirements. If an IBM supplied prompt does not meet your requirements, you can create a user-defined prompt containing only the fields you want.

For an example of creating a prompt, refer to Chapter 14, "Creating a User-Defined Prompt – Tutorial" on page 99.

Creating a Prompt

To create a prompt, do the following:

1. From the Edit display, type the P? or IP? line command, or press F23 (Select prompt). The Select Prompt display appears.
2. Press F23 (Select user prompt). The Select User-Defined Prompt display appears.

The following is an example of the Select User-Defined Prompt display with two previously created user-defined prompts:

```

                                Select User-Defined Prompt
Type information, press Enter.
Position to . . . . . —
Create a prompt . . . . . —

Type options, press Enter.
 1=Select   2=Change   4=Delete

Opt  Code  Prompt Text
—   CD   Customer Information
—   AB   Test Prompt
```

3. Type a prompt code in the *Create a prompt* prompt and press Enter. The Work with User-Defined Prompt Definition display appears.

You must identify each prompt that you create with a 1-character or 2-character alphabetic prompt code. You can use any combination of alphabetical characters, but if you create a user-defined prompt with the same prompt code as an IBM supplied prompt, your user-defined prompt will always appear when you request the prompt. You will not be able to access the IBM supplied prompt with the same prompt code.

4. Complete the *New field* prompt and the *Prompt text* prompt and press Enter. The User Prompt Field Description display appears, in which you can enter information about the title that SEU displays above the prompt.
5. Complete the fields on the User Prompt Field Description display and press Enter. The User Prompt Field Attribute display appears, on which you can enter information about the input field you are creating for the prompt.
6. Complete the fields on the User Prompt Field Attribute display and press Enter. The Work with User-Defined Prompt Definition display appears.

7. Press F10 (Save) to save the prompt.

To show a prompt while you are creating it, press F11 (Display prompt) on any of the user prompt displays. The following shows an example of the Display Prompt display.

```
Columns . . . : 1 71          Display Prompt          LIBRNAME01/FILENAME01
SEU==> _____ MEMBNAME01
FMT **  ...+... 1 ...+... 2 ...+... 3 ...+... 4 ...+... 5 ...+... 6 ...+... 7
          ***** Beginning of data *****
0001.00 This is a sample edit line.
0002.00 This is a sample edit line.
0003.00 This is a sample edit line.
0004.00 This is a sample edit line.
0005.00 This is a sample edit line.
Cust. Name - 24 chars.
_____
Cust. Address - 20 chars.
_____
Cust. City - 20 chars.
_____
Cust. Postal Code - 7 chars.
_____
```

You cannot type data on the Display Prompt display. Press any positional function key (Enter, Page Up, Page Down, F19, or F20) to return the user prompt display you were working on when you pressed F11 (Display prompt).

Changing a User-Defined Prompt

To change a user-defined prompt, do the following:

1. From the Edit display, type the P? or IP? line command, or press F23 (Select prompt). The Select Prompt display appears.
2. Press F23 (Select user prompt). The Select User-Defined Prompt display appears.
3. Type 2 (Change) in the *Opt* prompt beside the prompt you want to change, and press Enter. The Work with User-Defined Prompt Definition display appears.
4. Change the text in the *Prompt text* prompt, the prompt description, and the prompt attributes, and then press F10 (Save).

Selecting a User-Defined Prompt

After a user-defined prompt is created, you can select it by:

- Specifying the Pxx or IPxx line command on the Edit display. For example, to insert a new record using a user-defined prompt called CD, type IPCD in the sequence number area of the Edit display.
- Specifying the user-defined prompt code on the Select Prompt display. For example, to select the user-defined prompt CD using the Select Prompt display, type CD in the *Prompt type* prompt.
- Selecting the prompt from the Select User-Defined Prompt display. For example, to select the user-defined prompt CD, type 1 next to this prompt on the Select User-Defined Prompt display.

Defaults for Storage and Retrieval of User-Defined Prompts

SEU provides two files for storing prompts:

- The QASUPMT file contains all IBM supplied high-level-language (HLL) prompts
- The QASUUSRPMPT file contains user-defined prompts

When you create a user-defined prompt, SEU looks in your library list for the file QASUUSRPMPT and the member QASUUSRPMPT, and stores the prompt definition in this member. Prompts stored in this member can be shared by other users.

If you create a member in file QASUUSRPMPT with the same name as your user ID, SEU will store the prompt definition there instead of in member QASUUSRPMPT. No other user has access to prompts stored under your user ID.

If the file QASUUSRPMPT is not found when you try to save or create a user-defined prompt, SEU issues the following error message:

```
Cannot find prompt file *LIBL/QASUUSRPMPT.
```

Initially, the member QASUUSRPMPT is empty, and is stored in the file QGPL/QASUUSRPMPT. You can, however, move or duplicate it to any library in your library list. Member QASUPMT is stored in the file QPDA/QASUPMT. It cannot be moved to another file.

When you request a prompt on the Edit display, SEU searches the members of the files in the library list for the prompt in the following order:

1. *LIBL/QASUUSRPMPT *userid*
2. *LIBL/QASUUSRPMPT QASUUSRPMPT
3. QPDA/QASUPMT QASUPMT

If, after searching the prompt members, the prompt is still not found, SEU issues the following message:

```
Prompt or format not correct, or does not exist.
```

Restricting Access to Your User-Defined Prompts

Initially, SEU stores prompts that you create in the member QASUUSRPMPT in QGPL/QASUUSRPMPT. Prompts stored in this member can be displayed and changed by other users.

To restrict access to the prompts you defined, use the Add Physical File Member (ADDPFM) command to create a member in the file QASUUSRPMPT with the same name as your user ID. When you store or display prompts, SEU will always look for this member first before looking anywhere else for a place in which to store or retrieve prompts.

Creating Additional User-Defined Prompt Files

You can create additional QASUUSRPMPT files to store your user-defined prompts in libraries other than the initial default library QGPL.

To create another QASUUSRPMPT file, use the Create Duplicate Object (CRTDUPOBJ) command to create a copy of QGPL/QASUUSRPMPT in the library of your choice.

If you want to copy the existing members in QASUUSRPMPT that contain user-defined prompts to the new prompt file, specify *YES for *Duplicate data*. Otherwise, specify *NO.

If you specify *NO for the *Duplicate data* parameter, you must use the Add Physical File Member (ADDPFM) command to add new members to the new file.

Chapter 11. Exiting from Source Entry Utility

You can exit from SEU by using the Exit display. To access the Exit display, press F3 (Exit) on the Edit display or on any split display. You can use the Exit display to perform the following operations on the member you are editing:

- Exit and create a new member
- Exit without creating the member
- Exit and save an existing member with the changes you entered
- Exit without saving the changes to an existing member
- Resequence the member you edited
- Print the member
- Go to the member list (Work with Members Using SEU display)
- Return to editing
- Log Operation Control Language (OCL) statements
- Cancel the PDM find string function

For details on the prompts of the Exit display, press F1 (Help) to see the online help information.

Chapter 12. Creating a Source Member – Tutorial

In this tutorial, you create a source member EMPLY in source file QDDSSRC in library QGPL. The source member is source type PF.

The source member you create using DDS is for a database file consisting of two comment statements, one record-format statement, and three field statements. An example of the finished source member is shown in the following display.

Note: The spelling errors in the words NOME and DAPT are part of the tutorial, and are corrected in Chapter 13, “Changing a Source Member – Tutorial” on page 91.

```
Columns . . . : 1 71          Edit          QGPL/QDDSSRC
SEU==>          EMPLY
FMT A* .....A*. 1 ...+... 2 ...+... 3 ...+... 4 ...+... 5 ...+... 6 ...+... 7
***** Beginning of data *****
0001.00      A* EMPLOYEE FILE (EMPRPT)
0002.00      A*
0003.00      A          R INFOR
0004.00      A          NOME          20          COLHDG('NAME')
0005.00      A          DAPT          4          COLHDG('DEPT')
0006.00      A          PHONE        7          COLHDG('PHONE')
***** End of data *****

F3=Exit  F4=Prompt  F5=Refresh  F9=Retrieve  F10=Cursor
F16=Repeat find  F17=Repeat change  F24=More keys
(C) COPYRIGHT IBM CORP. 1994.
```

In this tutorial, you will be:

- “Starting a Session with the STRSEU Command”
- “Inserting Source Statements with the Insert Command” on page 86
- “Inserting Source Statements with a Format Line” on page 87
- “Inserting Source Statements with a Prompt” on page 88
- “Saving the Member” on page 90

Starting a Session with the STRSEU Command

To start an SEU session, do the following:

1. Type the following STRSEU command on the command line of the AS/400 Main Menu:

```
STRSEU SRCFILE(QGPL/QDDSSRC) SRCMBR(EMPLY) TYPE(PF)
OPTION(2) TEXT('Sample Program 5')
```

2. Press Enter. The Edit display appears.

The following message at the bottom of the display indicates that SEU added the new member to the file you specified:

Member EMPLY added to file QGPL/QDDSSRC.

3. The Edit display has blank lines because you are creating a new member. To remove the blank lines, press Enter.

Inserting Source Statements with the Insert Command

To insert source statements into a member, do the following:

1. Using the Insert (I) line command, type I2 on the left-hand side of the beginning-of-data line and press Enter, as shown in the following display:

```
Columns . . . : 1 71          Edit          QGPL/QDDSSRC
SEU==>                                     EMPLY
FMT PF .....A.....T.Name+++++RLen++TDpB.....Functions+++++
I2 ***** Beginning of data *****
***** End of data *****
```

Two blank lines are inserted, as shown in the following display:

```
Columns . . . : 1 71          Edit          QGPL/QDDSSRC
SEU==>                                     EMPLY
FMT PF .....A.....T.Name+++++RLen++TDpB.....Functions+++++
***** Beginning of data *****
:
:
***** End of data *****
```

2. Starting in column 6, which is under the A in the format line, type the first two statements of the source member, which are the comment statements, in the blank insert lines as shown in the following display.

```
Columns . . . : 1 71          Edit          QGPL/QDDSSRC
SEU==>                                     EMPLY
FMT PF .....A.....T.Name+++++RLen++TDpB.....Functions+++++
***** Beginning of data *****
:      A* EMPLOYEE FILE (EMPRPT)
:      A*
***** End of data *****
```

3. Press Enter. SEU inserts the statements in the member, assigns sequence numbers to them, and inserts a blank line after the last statement.

4. To remove the blank line that SEU inserted, press Enter again.

Inserting Source Statements with a Format Line

To insert source statements using a format line, do the following:

- Using the Insert-with-Format (IF) command, type IFPF2 in sequence number 0002.00, as shown in the following display, and press Enter:

```
Columns . . . : 1 71          Edit          QGPL/QDDSSRC
SEU==>
FMT A* .....A*. 1 ...+... 2 ...+... 3 ...+... 4 ...+... 5 ...+... 6 ...+... 7.
***** Beginning of data *****
0001.00      A* EMPLOYEE FILE (EMPRPT)
IFPF2       A*
***** End of data *****
```

The IFPF2 command inserts the PF format line and two blank lines as shown in the following display:

```
Columns . . . : 1 71          Edit          QGPL/QDDSSRC
SEU==>
FMT A* .....A*. 1 ...+... 2 ...+... 3 ...+... 4 ...+... 5 ...+... 6 ...+... 7.
***** Beginning of data *****
0001.00      A* EMPLOYEE FILE (EMPRPT)
0002.00      A*
FMT PF .....A.....T.Name+++++RLen++TDpB.....Functions+++++
''''''''
''''''''
***** End of data *****
```

- Using the format line as a guide, type the next two source statements, which are the record format statement and the first field statement, in the blank lines as shown in the following display.

Note: Type NOME as indicated. This spelling error is corrected in Chapter 13, “Changing a Source Member – Tutorial” on page 91.

```
Columns . . . : 1 71          Edit          QGPL/QDDSSRC
SEU==>
FMT A* .....A*. 1 ...+... 2 ...+... 3 ...+... 4 ...+... 5 ...+... 6 ...+... 7.
***** Beginning of data *****
0001.00      A* EMPLOYEE FILE (EMPRPT)
0002.00      A*
FMT PF .....A.....T.Name+++++RLen++TDpB.....Functions+++++
''''''''      A          R INFOR
''''''''      A          NOME          20          COLHDG('NAME')
***** End of data *****
```

- With the cursor at the end of the second insert line, press Enter. SEU inserts the records in the member, assigns sequence numbers to them, and inserts another blank line.
- Press F5 (Refresh) to remove the format line and the blank line.

Inserting Source Statements with a Prompt

To insert source statements with a prompt, do the following:

1. Type SET EXPERT on the SEU command line, as shown in the following display, and press any positional function key such as Enter, Page Up, Page Down, F19 (Left), or F20 (Right). This sets the Edit display to full screen mode, which provides 4 more edit lines and displays short forms for most of the SEU language prompts.

```
Columns . . . : 1 71          Edit          QGPL/QDDSSRC
SEU==> SET EXPERT          EMPLY
FMT A* .....A* 1 ...+... 2 ...+... 3 ...+... 4 ...+... 5 ...+... 6 ...+... 7
***** Beginning of data *****
0001.00      A* EMPLOYEE FILE (EMPRPT)
0002.00      A*
0003.00      A          R INFOR
0004.00      A          NOME          20          COLHDG('NAME')
***** End of data *****
```

2. Using the Insert-with-Prompt (IP) line command, type IPPF in sequence number 0004.00, as shown in the following display, and press Enter:

```
Columns . . . : 1 71          Edit          QGPL/QDDSSRC
SEU==>          EMPLY
***** Beginning of data *****
0001.00      A* EMPLOYEE FILE (EMPRPT)
0002.00      A*
0003.00      A          R INFOR
IPPF         A          NOME          20          COLHDG('NAME')
***** End of data *****
```

SEU inserts the PF prompt at the bottom of the display. The fields of the prompt are separated and labeled, as shown in the following display.

```
Columns . . . : 1 71          Edit          QGPL/QDDSSRC
SEU==>          EMPLY
***** Beginning of data *****
0001.00      A* EMPLOYEE FILE (EMPRPT)
0002.00      A*
0003.00      A          R INFOR
0004.00      A          NOME          20          COLHDG('NAME')
***** End of data *****

Pmt  SeqNbr  NameType  Name      Ref  Len  DataType  Dec  Use
PF   '        '
     Functions
```

3. Type DAPT under the *Name* column, type 4 under the *Len* column, (press Field Exit to right-adjust the value), and type COLHDG('DEPT') under the *Function* column, as shown in the following display, and press Enter.

Note: Type DAPT as indicated. This spelling error is corrected in Chapter 13, "Changing a Source Member – Tutorial" on page 91.

```

Pmt  SeqNbr  NameType  Name      Ref  Len  DataType  Dec  Use
PF   '       -      DAPT_____  -   4    -         -   -
      Functions
      COLHDG('DEPT')_____

```

SEU enters the record into the member and assigns a sequence number, as shown in the following display:

```

Columns . . . : 1 71          Edit          QGPL/QDDSSRC
SEU=>          EMPLOY
***** Beginning of data *****
0001.00      A* EMPLOYEE FILE (EMPRPT)
0002.00      A*
0003.00      A          R INFOR
0004.00      A          NOME          20          COLHDG('NAME')
0005.00      A          DAPT          4          COLHDG('DEPT')
***** End of data *****

Pmt  SeqNbr  NameType  Name      Ref  Len  DataType  Dec  Use
PF   '       -      _____  -   -    -         -   -
      Functions
      _____

```

4. Type the last source statement in the prompt, and press Enter. The Edit display appears as shown in the following display.

```

Columns . . . . : 1 71          Edit          QGPL/QDDSSRC
SEU==>          EMPLOY          EMPLOY
***** Beginning of data *****
0001.00      A* EMPLOYEE FILE (EMPRPT)
0002.00      A*
0003.00      A          R INFOR
0004.00      A          NOME          20          COLHDG('NAME')
0005.00      A          DAPT          4          COLHDG('DEPT')
0006.00      A          PHONE          7          COLHDG('PHONE')
*****
***** End of data *****

Pmt  SeqNbr  NameType  Name          Ref  Len  DataType  Dec  Use
PF   '-----'
      Functions

```

5. Press F5 (Refresh) to remove the prompt and blank line.
6. Press F10 (Cursor) to move the cursor from the data area to the SEU command line.
7. Type SET EXPERT OFF and press Enter to remove full screen mode.

Saving the Member

To save the member you created, type FILE on the SEU command line as shown in the following display, and press Enter:

```

Columns . . . . : 1 71          Edit          QGPL/QDDSSRC
SEU==> FILE          EMPLOY          EMPLOY
FMT A* .....A* 1 ...+... 2 ...+... 3 ...+... 4 ...+... 5 ...+... 6 ...+... 7
***** Beginning of data *****
0001.00      A* EMPLOYEE FILE (EMPRPT)
0002.00      A*
0003.00      A          R INFOR
0004.00      A          NOME          20          COLHDG('NAME')
0005.00      A          DAPT          4          COLHDG('DEPT')
0006.00      A          PHONE          7          COLHDG('PHONE')
*****
***** End of data *****

```

The member is saved in the current library and file. The following message appears at the bottom of the display:

Member is being saved.

You exit from SEU, the AS/400 Main Menu is returned, and the following message is displayed:

Member EMPLOY added to file QGPL/QDDSSRC.

Source member EMPLOY is created and ready for use in Chapter 13, "Changing a Source Member – Tutorial" on page 91.

Chapter 13. Changing a Source Member – Tutorial

In this tutorial, you change the DDS statements in the source member created in Chapter 12, “Creating a Source Member – Tutorial” on page 85. The source member is EMPLY in source file QDDSSRC in library QGPL. Following is the SEU source listing for this member. The highlighted numbers in the source listing indicate areas of the source member that you will change.

```

5763PW1 V3R1M0 941105                SEU SOURCE LISTING
SOURCE FILE . . . . . QGPL/QDDSSRC
MEMBER . . . . . EMPLY
SEQNBR*...+... 1 ...+... 2 ...+... 3 ...+... 4 ...+... 5 ...+... 6 ...+...
 100   A* EMPLOYEE FILE (EMRPT)
 200   A* 1
 300   A
 400   A      2 NOME          20          COLHDG('NAME')
 500   A      3 DAPT          4          COLHDG('DEPT')
 600   A      PHONE          4 7          COLHDG('PHONE')
5
      * * * * E N D   O F   S O U R C E * * * *

```

The list of items in the following table shows the changes to make to the source member EMPLY. Each number in the list corresponds to a number on the preceding SEU source listing.

Item	Changes to the Source Member
1	Add the comment: CORRECTIONS MADE BY J.A.H. 09/07/94
2	Change NOME to NAME
3	Change DAPT to DEPT
4	Change 7 to 5
5	Copy a record in a split Edit/Browse session

In this tutorial, you will be:

- “Starting a Session from the Work with Members Using PDM Display” on page 92
- “Changing Records Directly” on page 92
- “Changing Records with a Format Line” on page 93
- “Changing Records with the SEU FIND Command” on page 94
- “Copying Records with the Split Edit/Browse Display” on page 94
- “Changing Records with a Prompt” on page 97
- “Saving the Changes” on page 98

An example of the source member as it appears on the Edit display after all changes are done is shown in the following display.

```

Columns . . . : 1 71          Edit          QGPL/QDDSSRC
SEU==>          EMPLOY     EMPLOY
FMT A* .....A*. 1 ...+... 2 ...+... 3 ...+... 4 ...+... 5 ...+... 6 ...+... 7
***** Beginning of data *****
0001.00      A* EMPLOYEE FILE (EMPRPT)
0002.00      A* CORRECTIONS MADE BY J.A.H. 09/07/94
0003.00      A          R INFOR
0004.00      A          NAME          20          COLHDG('NAME')
0005.00      A          DEPT          4          COLHDG('DEPT')
0006.00      A          PHONE         5          COLHDG('PHONE')
0007.00      A          MLADDR        20          COLHDG('ADDR')
***** End of data *****

```

Starting a Session from the Work with Members Using PDM Display

To start an SEU session from the Work with Members Using PDM display, do the following:

1. Type the STRPDM (Start PDM) command on the command line of the AS/400 Main Menu. Press Enter, and the AS/400 Programming Development Manager (PDM) display appears.
2. Select option 3 (Work with members) and press Enter. The Specify Members to Work With display appears.
3. Specify that you want to work with the source file QDDSSRC in library QGPL, with source member EMPLOY, and with type *ALL, and press Enter. The Work with Members Using PDM display appears.
4. Type option 2 (Edit) in the *Opt* prompt next to the member EMPLOY, and press Enter. The programming development manager (PDM) calls SEU, SEU calls the Edit display, and you see the source member EMPLOY.

For more information on using PDM, see *ADTS/400: Programming Development Manager*.

Changing Records Directly

To add CORRECTIONS MADE BY J.A.H. 09/07/94 to record 0002.00, Move the cursor to record 0002.00, type the change shown in the following display, and press Enter.

```

Columns . . . : 1 71          Edit          QGPL/QDDSSRC
SEU==>          EMPLOY     EMPLOY
FMT A* .....A*. 1 ...+... 2 ...+... 3 ...+... 4 ...+... 5 ...+... 6 ...+... 7
***** Beginning of data *****
0001.00      A* EMPLOYEE FILE (EMPRPT)
0002.00      A* CORRECTIONS MADE BY J.A.H. 09/07/94
0003.00      A          R INFOR
0004.00      A          NOME          20          COLHDG('NAME')
0005.00      A          DAPT          4          COLHDG('DEPT')
0006.00      A          PHONE         7          COLHDG('PHONE')
***** End of data *****

```

The record is changed.

Changing Records with a Format Line

To change a record with a format line, do the following:

1. To change NOME to NAME using the Format (F) line command, type F in sequence number 0004.00 and press Enter. The PF format line is inserted above record 0004.00 as shown in the following display.

```

Columns . . . : 1 71          Edit          QGPL/QDDSSRC
SEU==>
FMT A* .....A*. 1 ...+... 2 ...+... 3 ...+... 4 ...+... 5 ...+... 6 ...+... 7
***** Beginning of data *****
0001.00      A* EMPLOYEE FILE (EMPRPT)
0002.00      A* CORRECTIONS MADE BY J.A.H. 09/07/94
0003.00      A          R INFOR
FMT PF .....A.....T.Name+++++RLen++TDpB.....Functions+++++
0004.00      A          NOME          20          COLHDG('NAME')
0005.00      A          DAPT          4          COLHDG('DEPT')
0006.00      A          PHONE        7          COLHDG('PHONE')
***** End of data *****

```

Note: In this tutorial, SEU operations are requested one at a time so that you can see the result of each operation. You can, however, type the change on record 0002.00, and type the Format (F) line command, and then press Enter. Both operations are done at the same time.

2. On record 0004.00, under the *Name* field on the format line, type A over the O in NOME to correct the spelling.

The spelling is changed and the format line remains as shown in the following display:

```

Columns . . . : 1 71          Edit          QGPL/QDDSSRC
SEU==>
FMT A* .....A*. 1 ...+... 2 ...+... 3 ...+... 4 ...+... 5 ...+... 6 ...+... 7
***** Beginning of data *****
0001.00      A* EMPLOYEE FILE (EMPRPT)
0002.00      A* CORRECTIONS MADE BY J.A.H. 09/07/94
0003.00      A          R INFOR
FMT PF .....A.....T.Name+++++RLen++TDpB.....Functions+++++
0004.00      A          NAME          20          COLHDG('NAME')
0005.00      A          DAPT          4          COLHDG('DEPT')
0006.00      A          PHONE        7          COLHDG('PHONE')
***** End of data *****

```

3. Press F5 (Refresh) to remove the format line.

Note: The format line is removed when you exit from editing. You can also remove the format line by pressing F5 (Refresh) or by using the D (Delete) line command.

Changing Records with the SEU FIND Command

To use the SEU FIND command to find the string DAPT and change it to DEPT, do the following:

1. Press F10 (Cursor) to move the cursor from the data area to the SEU command line.
2. Type SET MATCH, and press Enter. The SET MATCH command is used to find only the character string that matches the case in the find string.
3. Type F 'DAPT' on the SEU command line, as shown in the following display:

```
Columns . . . . : 1 71          Edit          QGPL/QDDSSRC
SEU==> F 'DAPT'          EMPLY
FMT A* .....A*. 1 ...+... 2 ...+... 3 ...+... 4 ...+... 5 ...+... 6 ...+... 7
***** Beginning of data *****
0001.00      A* EMPLOYEE FILE (EMPRPT)
0002.00      A* CORRECTIONS MADE BY J.A.H. 09/07/94
0003.00      A          R INFOR
0004.00      A          NAME          20          COLHDG('NAME')
0005.00      A          DAPT          4          COLHDG('DEPT')
0006.00      A          PHONE        7          COLHDG('PHONE')
***** End of data *****
```

4. Press Enter or F16 (Repeat find). The cursor is moved to the first occurrence of the string.
5. Type E over the A in DAPT to correct the spelling error.

Note: You can also position the display to the record if you know the record sequence number. In this example, it is record 0005.00. If you type 5b (5 and a space) in any *Sequence number* field and press Enter, record 0005.00 becomes the first record.

Copying Records with the Split Edit/Browse Display

While editing a member, you can copy records from a browse member into the edit member using the split Edit/Browse display.

To copy a record from a browse member, do the following:

1. Press F15 (Browse/Copy options). The Browse/Copy Options display appears.
2. Select option 1 (Member) for the *Selection* prompt and N (No) for the *Copy all records* prompt. Specify that you want to work with browse/copy member MLGREFP in file QATTDDS in library QUSRTOOL.

Note: Source member MLGREFP in file QATTDDS in library QUSRTOOL is part of the Operating System/400* (OS/400*) system.

3. Press Enter. The split Edit/Browse display appears, with EMPLY in the edit session and MLGREFP in the browse session, as shown in the following display.

```

Columns . . . : 1 71          Edit          QGPL/QDDSSRC
SEU==>
FMT A* .....A*. 1 ...+... 2 ...+... 3 ...+... 4 ...+... 5 ...+... 6 ...+...
***** Beginning of data *****
0001.00      A* EMPLOYEE FILE (EMPRPT)
0002.00      A* CORRECTIONS MADE BY J.A.H. 09/07/94
0003.00      A          R INFOR
0004.00      A          NAME          20          COLHDG('NAME')
0005.00      A          DEPT          4          COLHDG('DEPT')
0006.00      A          PHONE        7          COLHDG('PHONE')
***** End of data *****

Columns . . . : 1 71          Browse          QUSRTOOL/QATDDDS
SEU==>
***** Beginning of data *****
0001.00      A* MLGREFP - Mailing list field reference file
0002.00      A          R MLGREFR          TEXT('Mailing list ref')
0003.00      A          MLACCT          5 0          COLHDG('Account' +
0004.00      A                                     'number')
0005.00      A          EDTCDE(X)

F3=Exit  F5=Refresh  F9=Retrieve  F10=Cursor  F12=Cancel
F16=Repeat find  F17=Repeat change  F24=More keys

```

4. Move the cursor to the SEU command line of the browse session, type SET MATCH, and press Enter.
5. Type F 'MLADDR' on the SEU command line, and press Enter. The first occurrence of the string is found in record 0016.00 in the browse session, as shown in the following display.

```

Columns . . . : 1 71          Browse          QUSRTOOL/QATDDDS
SEU==>
***** Beginning of data *****
0015.00      A          name search')
0016.00      A          MLADDR          20          COLHDG('Addr')
0017.00      A          MLCITY          20          COLHDG('City')
0018.00      A          MLSTAT          2          COLHDG('State')
0019.00      A          VALUES('AL' 'AK' 'AZ' +

F3=Exit  F5=Refresh  F9=Retrieve  F10=Cursor  F12=Cancel
F16=Repeat find  F17=Repeat change  F24=More keys
String 'MLADDR' found.

```

6. Use the Copy (C) line command to copy the record from the browse session to the edit session. Move the cursor to the sequence number area of record 0016.00 in the browse session (MLGLEFD), and type C.
7. Use the After Target line command, A, to insert the new record in the edit session. Move the cursor to the sequence number area of record 0006.00 in the edit session (EMPLY), and type A. The commands are shown in the following display.

```

Columns . . . : 1 71          Edit          QGPL/QDDSSRC
SEU==>          EMPLY
FMT A* .....A*. 1 ...+... 2 ...+... 3 ...+... 4 ...+... 5 ...+... 6 ...+...
***** Beginning of data *****
0001.00      A* EMPLOYEE FILE (EMPRPT)
0002.00      A* CORRECTIONS MADE BY J.A.H. 09/07/94
0003.00      A          R INFOR
0004.00      A          NAME          20          COLHDG('NAME')
0005.00      A          DEPT          4          COLHDG('DEPT')
A           A          PHONE         7          COLHDG('PHONE')
***** End of data *****

Columns . . . : 1 71          Browse        QUSRTOOL/QATTDSD
SEU==>          MLGREFP
***** Beginning of data *****
0015.00      A          name search')
C           A          MLADDR         20          COLHDG('Addr')
0017.00      A          MLCITY        20          COLHDG('City')
0018.00      A          MLSTAT        2          COLHDG('State')
0019.00      A          VALUES('AL' 'AK' 'AZ' +

F3=Exit  F5=Refresh  F9=Retrieve  F10=Cursor  F12=Cancel
F16=Repeat find  F17=Repeat change  F24=More keys
String 'MLADDR' found.

```

8. Press Enter. The record is copied from the browse session to the edit session, creating record 0007.00 in EMPLY as shown in the following display.

```

Columns . . . : 1 71          Edit          QGPL/QDDSSRC
SEU==>          EMPLY
FMT A* .....A*. 1 ...+... 2 ...+... 3 ...+... 4 ...+... 5 ...+... 6 ...+...
***** Beginning of data *****
0001.00      A* EMPLOYEE FILE (EMPRPT)
0002.00      A* CORRECTIONS MADE BY J.A.H. 09/07/94
0003.00      A          R INFOR
0004.00      A          NAME          20          COLHDG('NAME')
0005.00      A          DEPT          4          COLHDG('DEPT')
0006.00      A          PHONE         7          COLHDG('PHONE')
0007.00      A          MLADDR        20          COLHDG('Addr')
***** End of data *****

```

9. Press F12 (Cancel) to end the split Edit/Browse session. The Edit display appears with the new record as shown in the following display.

```

Columns . . . : 1 71          Edit          QGPL/QDDSSRC
SEU==>          EMPLY
FMT A* .....A*. 1 ...+... 2 ...+... 3 ...+... 4 ...+... 5 ...+... 6 ...+... 7
***** Beginning of data *****
0001.00      A* EMPLOYEE FILE (EMPRPT)
0002.00      A* CORRECTIONS MADE BY J.A.H. 09/07/94
0003.00      A          R INFOR
0004.00      A          NAME          20          COLHDG('NAME')
0005.00      A          DEPT          4          COLHDG('DEPT')
0006.00      A          PHONE         7          COLHDG('PHONE')
0007.00      A          MLADDR        20          COLHDG('Addr')
***** End of data *****

```

10. Move your cursor to record 0007.00 and type 'ADDR' over 'Addr' to change the column heading in the new record to capital letters.

Changing Records with a Prompt

To make changes with a prompt, do the following:

1. Type a P in sequence number 0006.00, and press Enter. Record 0006.00 is checked for the prompt type, and the contents of record 0006.00 are inserted in a prompt at the bottom of the display, as shown in the following display:

```

Columns . . . . : 1 71          Edit          QGPL/QDSSRC
SEU==>          _____          EMPLOY
FMT A* .....A*. 1 ...+... 2 ...+... 3 ...+... 4 ...+... 5 ...+... 6 ...+... 7
***** Beginning of data *****
0001.00      A* EMPLOYEE FILE (EMPRPT)
0002.00      A* CORRECTIONS MADE BY J.A.H. 09/07/94
0003.00      A          R INFOR
0004.00      A          NAME          20          COLHDG('NAME')
0005.00      A          DEPT           4          COLHDG('DEPT')
0006.00      A          PHONE          7          COLHDG('PHONE')
0007.00      A          MLADDR         20          COLHDG('ADDR')
***** End of data *****

Prompt type . . .  PF      Sequence number . . . 0006.00

Name
Type      Name          Ref      Length  Data   Decimal  Use
          PHONE_____ -        7      -      -      -
Functions
COLHDG('PHONE')_____

F3=Exit  F4=Prompt  F5=Refresh  F9=Retrieve  F10=Cursor
F16=Repeat find  F17=Repeat change  F24=More keys

```

2. Type 5 under the *Length* field, and press Field Exit to right-adjust the value. The prompt appears as shown in the following display:

```

Prompt type . . .  PF      Sequence number . . . 0006.00

Name
Type      Name          Ref      Length  Data   Decimal  Use
          PHONE_____ -        5      -      -      -
Functions
COLHDG('PHONE')_____

F3=Exit  F4=Prompt  F5=Refresh  F9=Retrieve  F10=Cursor
F16=Repeat find  F17=Repeat change  F24=More keys

```

3. Press Enter. The record is changed. The prompt operation is a repeating operation, so the next record is inserted in the prompt as shown in the following display.

```

Columns . . . . : 1 71          Edit          QGPL/QDSSRC
SEU==>          EMPLOY
FMT A* .....A*. 1 ...+... 2 ...+... 3 ...+... 4 ...+... 5 ...+... 6 ...+... 7
***** Beginning of data *****
0001.00      A* EMPLOYEE FILE (EMPRPT)
0002.00      A* CORRECTIONS MADE BY J.A.H. 09/07/94
0003.00      A          R INFOR
0004.00      A          NAME          20          COLHDG('NAME')
0005.00      A          DEPT          4          COLHDG('DEPT')
0006.00      A          PHONE         5          COLHDG('PHONE')
0007.00      A          MLADDR        20          COLHDG('ADDR')
***** End of data *****

Prompt type . . . PF          Sequence number . . . 0007.00

Name
Type      Name      Ref      Length  Data      Decimal
          MLADDR    _      _20      _         _         Use
Functions
COLHDG('ADDR')_____

F3=Exit  F4=Prompt  F5=Refresh  F9=Retrieve  F10=Cursor
F16=Repeat find  F17=Repeat change  F24=More keys

```

4. Press F5 (Refresh) to remove the prompt.

Saving the Changes

To save the changes to member EMPLY, do the following:

1. Press F3 (Exit) to show the Exit display. Because you made changes to the source member, a Y (Yes) is displayed in the *Change/create member* prompt as shown in the following display.

```

                                Exit
Type choices, press Enter.
Change/create member . . . . . Y          Y=Yes, N=No
Member . . . . . EMPLY          Name, F4 for list
File . . . . . QDSSRC          Name, F4 for list
Library name . . . . . QGPL          Name
Text . . . . . _____

-----
Resequence member . . . . . Y          Y=Yes, N=No
Start . . . . . 0001.00        0000.01-9999.99
Increment . . . . . 01.00      0.01-99.99

Print member . . . . . N          Y=Yes, N=No
Return to editing . . . . . N          Y=Yes, N=No
Go to member list . . . . . N          Y=Yes, N=No

F3=Exit  F4=Prompt  F5=Refresh  F12=Cancel

```

Note: To bypass the Exit display, type FILE on the SEU command line, and press Enter.

2. Press Enter to process the changes to the member, exit from SEU, and return to the Work with Members Using PDM display.

Chapter 14. Creating a User-Defined Prompt – Tutorial

The following tutorial shows how to create a user-defined prompt for a database that consists of customer names and addresses.

In this tutorial, a user-defined prompt called CD (customer data) is created, and then the following fields for the CD prompt are created:

- CUSTNAME
- CUSTADDRESS
- CUSTCITY
- CUSTPOSTAL

The following display shows what the prompt looks like when you are finished:

```
Columns . . . : 1 71          Display Prompt          LIBRNAME01/FILENAME01
SEU==>          MEMBNAME01
...+... 1 ...+... 2 ...+... 3 ...+... 4 ...+... 5 ...+... 6 ...+... 7 ...+...
***** Beginning of data *****
0001.00 This is a sample edit line.
0002.00 This is a sample edit line.
0003.00 This is a sample edit line.
0004.00 This is a sample edit line.
0005.00 This is a sample edit line.
0006.00 This is a sample edit line.
0007.00 This is a sample edit line.
0008.00 This is a sample edit line.
Cust. Name - 24 chars.
-----
Cust. Address - 20 chars.
-----
Cust. City, Country - 20 chars
-----
Cust. Postal Code - 7 chars.
-----
F3=Exit  F4=Prompt  F5=Refresh      F11=Previous record
F12=Cancel  F23=Select prompt  F24=More keys
Press any function key to return to the User-Defined Prompt Definition display.
```

In this tutorial, you will be:

- “Defining a Prompt Code”
- “Creating a Field for the Prompt” on page 100
- “Displaying and Saving the Prompt” on page 101

Defining a Prompt Code

1. To define a user-defined prompt, type the P? or IP? line command, or press F23 (Select prompt) on the Edit display. You see the Select Prompt display for AS/400 member types.
2. Press F23. You see the Select User-Defined Prompt display.
3. Type CD in the *Create a prompt* prompt to specify the prompt code you want to define, and press Enter.

You see the Work with User-Defined Prompt Definition display.

4. Because this is a new prompt, specify text for the CD prompt code you just created. You can specify up to 50 characters to describe the prompt code. Type `Customer Information` in the *Prompt text* prompt.

Note: If you press Enter without typing information in any of the prompts on the Work with User-Defined Prompt Definition display, SEU returns to the Select User-Defined Prompt display.

Creating a Field for the Prompt

1. To create a field for customer names, type `CUSTNAME` in the *New field* field of the Work with User-Defined Prompt Definition display, and press Enter. You see the User Prompt Field Description display, which is used for defining a field description appears. A field description is the title SEU shows above an input field in the prompt.

The *Prompt code*, *Prompt text*, and *Field name* fields display the information you enter. The other fields on the display show the default values that you can change.

2. Type the following:
 - a. `Cust. Name - 24 chars.` in the *Field text* prompt
 - b. `13` in the *Line on display* prompt
 - c. `1` in the *Column on display* prompt

When SEU shows the prompt, the `CUSTNAME` heading appears on line 13, starting in column 1.

3. Press Enter. You see the User Prompt Field Attribute display which is used for defining an input field. Field attributes describe the input field you are creating for the prompt.

4. Type the following:
 - a. `14` in the *Line on display* prompt
 - b. `01` in the *Column on display* prompt
 - c. `1` in the *Data type* prompt
 - d. `24` in the *Length* prompt
 - e. `001` in the *Column in source record* prompt
 - f. `Y` in the *Highlight* prompt
 - g. `N` in the *Reverse Image* prompt
 - h. `N` in the *Column Separator* prompt
 - i. `Y` in the *Underline* prompt

This is the first input field for the prompt you are creating, and it appears on the Edit display immediately below the `CUSTNAME` heading.

5. Press Enter. SEU saves the new field and returns to the Work with User-Defined Prompt Definition display.

From the Work with User-Defined Prompt Definition display you can change or delete the existing field (`CUSTNAME`), define another field for the prompt, or return to the Select Prompt display.

Note: If you want to return the Edit display without creating any more prompt fields, press F10 (Save) to save the prompt field definitions you have created so far.

To define the three remaining fields for the CD prompt, repeat the steps in “Creating a Field for the Prompt” on page 100, using the field information shown in the following table.

Field Name	Field Text	Line on Display	Column on Display	Data Type	Length	Column in Source Record
CUSTADDRES	Cust. Address - 20 chars.	15	1	Alphameric	20	25
CUSTCITY	Cust. City, Country - 20 chars.	17	1	Alphameric	20	45
CUSTPOSTAL	Cust. Postal Code - 7 chars.	19	1	Alphabetic	7	65

When you finish adding the fields for the CD prompt, you see the prompt and all the defined fields on the Work with User-Defined Prompt Definition display, as shown in the following display:

```

Work with User-Defined Prompt Definition

Prompt code . . . . . : CD

Type information, press Enter.
Position to . . . . . _____ Name
New field . . . . . _____ Name, SEQUENCE
Prompt text . . . . Customer Information_____

Type options, press Enter.
1=Define description      2=Define attribute      4=Delete
Opt  Field Name  Field Text
-    CUSTNAME    Cust. Name - 24 chars.
-    CUSTADDRES  Cust. Address - 20 chars.
-    CUSTCITY    Cust. City, Country - 20 chars.
-    CUSTPOSTAL  Cust. Postal Code - 7 chars.

F3=Exit  F5=Refresh  F10=Save
F11=Display prompt  F12=Cancel

Bottom

```

Displaying and Saving the Prompt

To display and save a prompt, do the following:

1. Press F11 (Display prompt) on the Work with User-Defined Prompt Definition display. You see what the prompt looks like on the Edit display, as shown in the following display.

```

Columns . . . : 1 71          Display Prompt          LIBRNAME01/FILENAME01
SEU=>          MEMBNAME01
...+... 1 ...+... 2 ...+... 3 ...+... 4 ...+... 5 ...+... 6 ...+... 7 ...+...
***** Beginning of data *****
0001.00 This is a sample edit line.
0002.00 This is a sample edit line.
0003.00 This is a sample edit line.
0004.00 This is a sample edit line.
0005.00 This is a sample edit line.
0006.00 This is a sample edit line.
0007.00 This is a sample edit line.
0008.00 This is a sample edit line.
Cust. Name - 24 chars.
-----
Cust. Address - 20 chars.
-----
Cust. City, Country - 20 chars
-----
Cust. Postal Code - 7 chars.
-----

F3=Exit  F4=Prompt  F5=Refresh          F11=Previous record
F12=Cancel      F23=Select prompt  F24=More keys
Press any function key to return to the User-Defined Prompt Definition display.

```

2. Press any function key to return the Work with User-Defined Prompt Definition display.
 3. From the Work with User-Defined Prompt Definition display, press F10 (Save) and then F12 (Cancel) to return to the Select User-Defined Prompt display.
- Note:** If you do not want to return to the Select User-Defined Prompt display, press F10 (Save), then F3 (Exit).

Appendix A. SEU in the System/36 Environment

You can use AS/400 SEU in the System/36 environment with either the development support utility (DSU) or the SEU procedure.

The DSU Procedure

If you are running in the System/36 environment, you can call AS/400 SEU by using the System/36 DSU procedure. The parameters of the DSU procedure are interpreted to call AS/400 SEU in a predictable manner.

Syntax

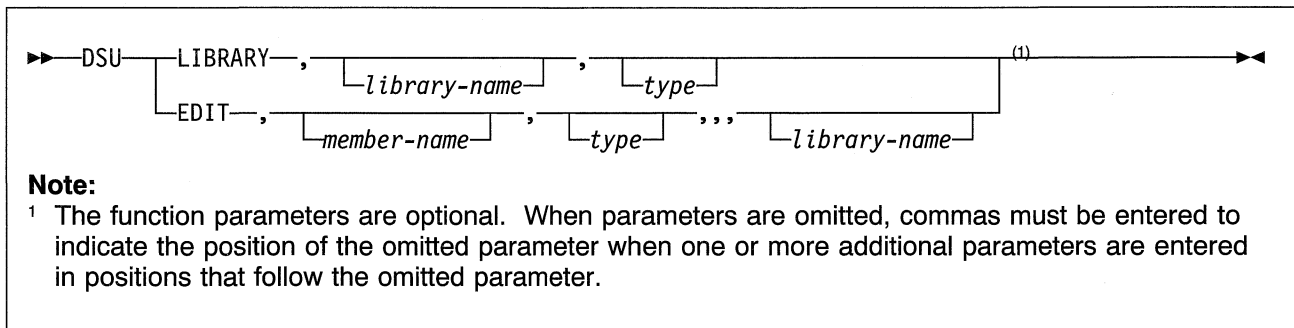

Specify the function AS/400 SEU performs. This is a required parameter. The possible parameters are:

LIBRARY

Calls the Work with Members Using SEU display.

You can specify the following parameters:

library-name

The library that contains the library members to be edited or created. The default is the current library (*CURLIB).

type

The member type to be listed. The possible parameters are:

SOURCE or **S**

Source type. A list of source members from file QS36SRC is shown.

PROC or **P**

Procedure type. A list of procedure members from file QS36PRC is shown.

EDIT

Calls the Edit display for the member. You can specify the following parameters:

member-name

The name of the source member or procedure member to be edited or created.

type

The member type to be edited or created. The possible parameters are:

SOURCE or **S**

Source type. An edit session with the member in the source physical file QS36SRC is started.

PROC or **P**

Procedure type. An edit session with the member in the source physical file QS36PRC is started.

A The source member contains RPG auto-report specifications. An edit session with the member in the source physical file QS36SRC is started.

- F** The source member contains \$SFGR display format S, H, and D specifications. An edit session with the member in the source physical file QS36SRC is started.
- R** The source member contains an RPG II program. An edit session with the member in the source physical file QS36SRC is started.
- T** A message source member. An edit session with the member in the source physical file QS36SRC is started.

- W** The source member contains Work Stations Utility (WSU) statements. An edit session with the member in the source physical file QS36SRC is started.

library-name

The library that contains the library members to be edited or created. The default is the current library (*CURLIB).

How DSU Procedure Parameters Map to STRSEU Parameters

The following table summarizes how the DSU procedure parameters map to the AS/400 STRSEU command parameters.

DSU Parameter	AS/400 STRSEU Parameter
Function	<ul style="list-style-type: none"> • Function=LIBRARY causes the OPTION parameter of AS/400 SEU to be set to *SELECT. • Function=EDIT causes the OPTION parameter to be set to 2 (Edit).
Library	Maps to the library name of SRCFILE
Type	Maps the file of SRCFILE to QS36SRC or QS36PRC
Member name	Maps to the member name of SRCMBR
Format member	Not used by AS/400 SEU
Statement length	Not used by AS/400 SEU
Diagnosed source file	Not used by AS/400 SEU
Display size	Not used by AS/400 SEU

The SEU Procedure

If you are running the System/36 environment, you can call AS/400 SEU by using the System/36 SEU procedure. The parameters of the System/36 SEU procedure are interpreted to call AS/400 SEU correctly.

Syntax

▶—SEU—*member-name*⁽¹⁾—, ——, , , ——▶

Note:

¹ The remaining parameters are optional. When parameters are omitted, commas must be entered to indicate the position of the omitted parameter when one or more additional parameters are entered in positions that follow the omitted parameter.

member-name

Name of the source or procedure member to be edited or created.

type

The member type to be edited or created. The possible values are:

SOURCE or **S**

Source type. An edit session with a member in the source physical file QS36SRC is started.

PROC or **P**

Procedure type. An edit session with a member in the source physical file QS36PRC is started.

- A** The source member contains RPG auto-report specifications. An edit session with a member in the source physical file QS36SRC is started.

- F** The source member contains \$SFGR display format S, H, and D specifications. An edit session with a member in the source physical file QS36SRC is started.

- R** The source member contains an RPG II program. An edit session with a member in the source physical file QS36SRC is started.

- T** A message source member. An edit session with a member in the source physical file QS36SRC is started.

- W** The source member contains Work Station Utility (WSU) statements. An edit session with a member in the source physical file QS36SRC is started.

library-name

The library that contains the library member to be edited or created. The default is the current library (*CURLIB).

How SEU Procedure Parameters Map to STRSEU Parameters

The following table summarizes how the System/36 SEU procedure parameters map to AS/400 STRSEU command parameters.

System/36 SEU Parameter	AS/400 STRSEU Parameter
Member name	Maps to the member name of SRCMBR
Type	Maps the file of SRCFILE to QS36SRC or QS36PRC
Format member	Not used by AS/400 SEU
Statement length	Not used by AS/400 SEU
Library	Maps to the library name of SRCFILE
Diagnosed source file	Not used by AS/400 SEU

Appendix B. SEU in the System/38 Environment

You can use the EDTSRC command to use SEU in the System/38 environment.

The EDTSRC Command

To call SEU, type the EDTSRC command.

Syntax

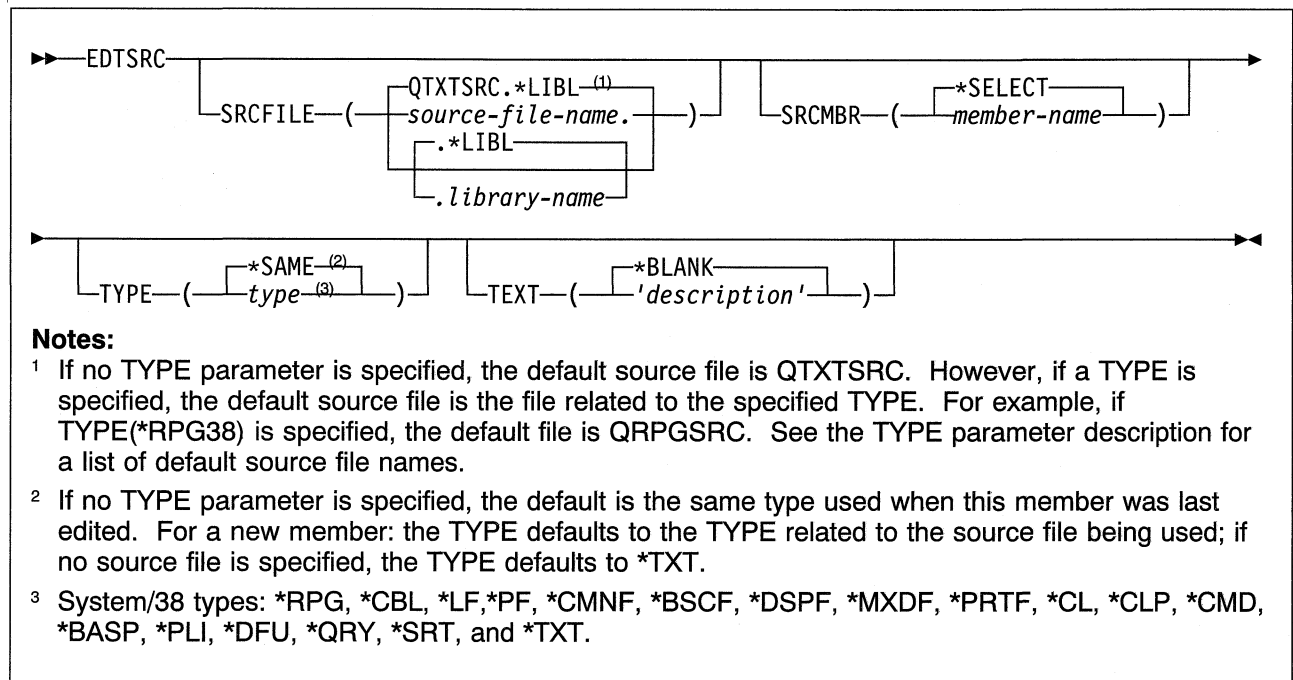

Notes:

- ¹ If no TYPE parameter is specified, the default source file is QTXTSRC. However, if a TYPE is specified, the default source file is the file related to the specified TYPE. For example, if TYPE(*RPG38) is specified, the default file is QRPGRSRC. See the TYPE parameter description for a list of default source file names.
- ² If no TYPE parameter is specified, the default is the same type used when this member was last edited. For a new member: the TYPE defaults to the TYPE related to the source file being used; if no source file is specified, the TYPE defaults to *TXT.
- ³ System/38 types: *RPG, *CBL, *LF,*PF, *CMNF, *BSCF, *DSPF, *MXDF, *PRTF, *CL, *CLP, *CMD, *BASP, *PLI, *DFU, *QRY, *SRT, and *TXT.

SRCFILE: Specify the name of the source physical file that contains the member to be edited or created.

you do not qualify the source file name, SEU uses the library list (*LIBL) to find the file.

QTXTSRC

This default value specifies QTXTSRC as the default source physical file if you do not specify a TYPE parameter. If you specify a TYPE parameter, the default value specifies the file related to the specified TYPE as the source file. For example, if you specify Type (*RPG), the default source file is QRPGRSRC. See the TYPE parameter description for a list of default source files.

source-file-name

This value allows you to specify the name of an existing source physical file. Optionally, you can qualify the source file name with the name of the library that contains the file. If

SRCMBR: Specify the name of the source file member to be edited or created.

***SELECT**

This default value directs SEU to display a list of all members in the file for you to edit, browse, print, or delete. On the list of members, you type the name of a member to be created or edited, search for a member name, change the type and text of an existing member, or change the TYPE and TEXT parameters for new members.

member-name

This value allows you to specify a name for the member you want to create or edit.

TYPE: Specify the type of source to be edited or created.

Notes:

1. While type names in System/38 commands must be prefixed by an asterisk (*), the OS/400 system requires that the first character of a type name be alphanumeric. The OS/400 system converts System/38-style type names to ones that are valid for the AS/400 system by removing the asterisk and appending 38 to the type name.

If you specify *SAME for the member type, the conversion described above is done implicitly. For example, if you use the EDTSRC command to edit a member with a type of CLP and specify *SAME for the type, the OS/400 system does an implicit substitution of *CLP for *SAME, and then converts the type to CLP38.

2. On the EDTSRC command, the TYPE value begins with an asterisk (for example, *RPG or *DSPF). On the options displays, Work with Members Using SEU display, and Programmer menu, the asterisk is not used (for example, RPG or DSPF).

***SAME**

This default value directs SEU to use the same type as that used when this member was last edited. For a new member, the default value is the type related to the source file you are using. If a source file is not specified, the default value is *TXT.

type

This value allows you to specify the type of source to use. The following table lists the possible values you can specify as the type. It also lists the default source (the source file used if you do not specify a value for SRCFILE) and the source language for which the type is used.

Type Specified	Default Source File	Source Language
*TXT	QTXTSRC	80-position free-form text
*SRT	QTXTSRC	Reformat
*CL	QCLSRC	Control Language (CL)
*CLP	QCLSRC	CL Program

Type Specified	Default Source File	Source Language
*CMD	QCMDSRC	CL Command Definition
*PF	QDDSSRC	DDS Physical File
*LF	QDDSSRC	DDS Logical File
*CMNF	QDDSSRC	DDS Communications File
*BSCF	QDDSSRC	DDS Binary Synchronous Communications File
*DSPF	QDDSSRC	DDS Display Device File
*MXDF	QDDSSRC	DDS Mixed File
*PRTF	QDDSSRC	DDS Printer Device File
*RPG	QRPGSRC	RPG III
*CBL	QCBLSRC	COBOL
*BAS	QBASSRC	BASIC
*BASP	QBASSRC	BASIC Procedure
*PLI	QPLISRC	PL/I
*DFU	QUDSSRC	UDS Data File Utility
*QRY	QUDSSRC	UDS Query Utility

TEXT: Specify a character string to be stored in the text field of a member.

***BLANK**

For a new member, this default value directs SEU to enter blanks in the *Text* field of the member. For an existing member, this default value does not change the *Text* field of the member.

description

This value allows you to specify a character string that describes a member. You can specify a maximum of 50 characters. Enclose the string in apostrophes to use leading or trailing blanks.

Appendix C. Double-Byte Character Sets

You can use SEU to enter and modify double-byte character set (DBCS) strings.

The following sections deal only with the aspects of DBCS that are specific to SEU. For more information on working with DBCS data, refer to the *Data Management*, SC41-3710.

Enabling DBCS for SEU

To enter DBCS in source members in SEU:

- You must be using a DBCS-capable workstation.
- Ensure that the source file in which the member is located specifically allows DBCS data.

When you create a source physical file by using the CRTSRCPF command, you must specify the IGCDTA(*YES) parameter to indicate that the file will contain members with DBCS data.

Note: If you open a member in an IGCDTA(*YES) source file on a non-DBCS-capable workstation, the DBCS data will be illegible. Any attempt to alter the DBCS data can lead to data corruption.

For more information about AS/400 commands, see the *CL Reference*. For more information about creating DBCS-capable source files, see the *Data Management*.

Using DBCS with SEU Displays

You can enter DBCS data in certain prompts in several of the SEU displays. SEU performs special processing on DBCS data to maintain the appropriate placement of shift-out and shift-in characters.

Double-byte characters are physically larger than alphanumeric characters. In system displays, double-byte characters are twice as wide as alphanumeric characters.

Consider the width of double-byte characters when you calculate the length of a double-byte data field, because field lengths are still identified as the number of alphanumeric character positions used. DBCS-graphic character fields are the exception to this rule. The length of these fields is the number of double-byte characters, not the number of bytes.

When using DBCS on SEU displays, keep in mind that if the member that you are editing or browsing is not contained in a source file that allows DBCS characters, then you cannot enter DBCS characters on any of the SEU displays while editing or browsing members with the Edit or Browse displays, or when saving your files with the Exit display.

Displays That Accept DBCS Data

The following table shows the displays and fields on which you can enter DBCS data:

Display	Field
Browse	SEU command line
Edit	Data records, SEU command line, and fields in a prompt (depending on the prompt)
Exit	<i>Text</i> (if the member is in a DBCS-capable file)
Find/Change Options	<i>Find</i> and <i>Change</i>
Find Options	<i>Find</i>
Subset Member List	<i>Text</i>
Work with Members Using SEU	<i>Text</i> for new member and <i>Text</i>

AS/400 Prompts and Fields That Accept DBCS Data

The following table shows the prompts and associated fields that you can use to enter DBCS data into data records:

AS/400 Prompt	Field
RH	Comments, Program Identification
RR	Comments
RF	Comments
RC	Constant, Comments
MD	Constant
MC	Constant data
CC	Comments
FT	Prompt
F*	Comment

System/36 Prompts and Fields That Accept DBCS Data

The following table shows the prompts and associated fields that you can use to enter DBCS data into data records:

System/36 Prompt	Field
H, F, G, U, E, L	Comments
T, I, J, 1A, O, OA, K	Comments
C	Factor1, Factor2, Comments
P	Constant-edit word, Comments
FD	Constant

System/36 Prompt	Field
FC	Constant data
CO	Area A, Area B, Comments
SH, SR, SF, AU, CC, FO	Comments
SC	Constant, Comments
AS	Both Comment fields
FF	Column counter (unlabeled input field)
MS	Message text
MH	User comments
C*	Column counter (unlabeled input field)

Note: In source physical files marked IGCDTA(*YES), the insert prompts and formats for the RPG II control specifications show a field for column 57 (the transparent literal field).

System/38 and AS/400 Prompts and Fields That Accept DBCS Data

The following table shows the prompts and associated fields that you can use to enter DBCS data into data records:

System/38 and AS/400 Prompt	Field
**	Columns counter (unlabeled input field)
E	Comment
C	Factor1, Factor2, Comment
P	Constant-edit word
*	Comment (unlabeled input field)
A*	Comment (unlabeled input field)
LF	Functions
PF	Functions
DP	Functions
BC	Functions
CB	Area-A, Area-B
C*	Comment (unlabeled input field)
RH	Comments, Statement Set name
RF	Comments, Statement Set name
RR	Comments, Statement Set name
NC	Column Counter (unlabeled input field)

Considerations for Using DBCS on SEU Displays

When SEU shows parts of a string of DBCS data (such as when DBCS data stretches beyond the length of a line on the display), SEU inserts temporary shift-out (0_E) or shift-in (0_F) characters and, if necessary, inserts a temporary DUP (*) character as a filler character. SOSI is shown in the sequence number area to remind you that the entire string of DBCS data can be viewed by using F19 (Left) and F20 (Right) keys. For example, the DBCS string 0_EK1K2K30_F is shown as follows when the edge of the display (indicated by |) comes between two double-byte characters (K2 and K3):

```
0EK1K2K30F
0EK10F|
```

When the edge of the display comes between the first and second byte of a double-byte character (for example, K2), both a temporary shift-in and a temporary DUP character (indicated here by *) are inserted as shown:

```
0EK1K2K30F
0EK10F*|
```

Do not move or delete these temporary characters or any control character that appears at the edge of the source field. If you do, SEU shows the line again without the changes you requested and indicates that you made an error. These considerations also apply to DBCS strings that are designated as DBCS-graphic. In source code shown by SEU, the shift characters are required.

Note: The rules for processing DBCS data across multiple lines in prompts (to allow entering one continuous DBCS character string) are the same as those adopted by the Interactive SQL Utility. Each line must contain as many shift-in characters as shift-out characters. If during formatting, however, the prompter finds that the very last column on a line contains a shift-in and the very first column of the next line contains a shift-out, the shift-in and shift-out characters are removed by the prompter when the two lines are assembled. Also, if the last two columns of a line contain a shift-in character followed by a single-byte blank, and the very first column of the next line contains a shift-out character, the shift-in, blank, and shift-out sequence is removed by the prompter when the two lines are assembled.

An unavoidable situation can arise as a result of the rules above. When a DBCS character string must be continued on more than one source line, additional shift-out and shift-in characters may be inserted by the prompter.

DBCS in Split Displays

When you are using DBCS in a split display, whether the options displays are DBCS-capable is dependent on the member in the top session. The options displays for both sessions are DBCS-capable if the member in the top session is DBCS-capable; if the member in the top session is not DBCS-capable, the options displays for both sessions are not DBCS-capable.

When you use the split Edit/Browse display to edit a member of a source file that is DBCS-capable, you can enter DBCS characters in the following fields:

- *Data record* field of the edit session of the split display
- Find parameters for the SEU FIND and CHANGE commands for the edit session of a split display
- Find parameters for the SEU FIND command for the browse session of a split display

You can copy records from the browse member to the edit member. If SEU must truncate the copied records, SEU adds any required shift-in control characters.

If you edit a member from a source file that does not allow DBCS data, you can still browse a member, spooled file, or database file that contains DBCS data. SEU indicates possible errors if you copy records from the member with DBCS data into the member that does not allow DBCS data.

Note: SEU does not prevent you from copying records from a member that allows DBCS characters to a member that does not allow DBCS characters when you are in a split Edit/Browse display. SEU will do such copy operations as they are specified, and will allow you to save the member in a non-DBCS-capable file. The OS/400 system, however, will not recognize the data as DBCS. You may encounter difficulties the next time you try to work with a member in a non-DBCS-capable file that contains records copied from a DBCS-capable member.

When you use either split display to browse a spooled file, data base file, or source file member that contains DBCS data, SEU can show DBCS data in the *Record* field.

If the member displayed in the top session is contained in a DBCS-capable file, you can do the following:

- You can enter DBCS data in the *Find* field on the Find Options display
- You can enter DBCS data in the *Find* and *Change* fields on the Find/Change Options display

For more information on working with split displays, see “Splitting the Browse Display” on page 16 and “Splitting the Edit Display” on page 19.

Using DBCS with SEU Commands and Functions

You can use double-byte characters with the following SEU functions:

- Find and change operations
- Saving members
- Printing

Finding and Changing DBCS Strings

You can use DBCS data in the *Find* and *Change* fields of the Edit, Browse, Find Options, Find/Change Options displays and the Find and Change parameters of the SEU FIND and CHANGE commands. SEU processes the shift-control characters as follows:

- If the first character in the string to be found is a shift-out character, SEU removes that character from the string. If the last character in the string to be found (other than a blank) is a shift-in character, SEU removes that character from the Find string. SEU, however, matches this string only to characters that are enclosed within shift-control characters, or that are part of a longer string of characters enclosed by shift-control characters.
- If you want to search for a string that begins with a shift-out character or that ends with a shift-in character, enclose the string in apostrophes (') or quotation marks ("). In other cases, SEU searches for the string entered in the *Find* field or in the Find parameter.
- SEU treats shift-control characters in the change string the same ways as it treats them in the find string. If the find string begins or ends with shift-control characters, the change string must also begin or end with shift-control characters.

The following table shows how to find DBCS strings.

To Find This String	Specify This String
K1K2	0 _E K1K20 _F
0 _E K1K20 _F	'0 _E K1K20 _F '
K20 _F AB	0 _E K20 _F AB
AB0 _E K1	AB0 _E K10 _F

Printing DBCS Source Data

On the Work with Members Using SEU and Exit displays, you can request the printing of a source member. When the source member contains DBCS data, print the data on a DBCS printer.

Considerations for Using DBCS with SEU Commands

Consider the following when using DBCS data with SEU:

- On the Exit display, you can specify the name of the member, file, and library in which your edited member is to be stored. However, you cannot store changes you have made to a DBCS-capable file member in a non-DBCS-capable file member.
- If SEU truncates the stored records, it adds any required shift-in characters.

- On the Change Session Defaults display, the *Uppercase input only* field does not apply to DBCS data. Unlike many languages, where an A is considered functionally equivalent to an a, an uppercase DBCS Roman letter is always treated as a distinct character from the corresponding lowercase DBCS Roman letter.

DBCS Conversion in SEU

You can use DBCS conversion to enter DBCS data in SEU. DBCS conversion is an alternative to directly typing double-byte data. It lets you type an alphanumeric entry or double-byte character code and convert the entry or code to its related double-byte word. DBCS conversion is intended for Japanese character sets and its use is limited for application to other double-byte character sets.

To do DBCS conversion:

1. Position the cursor in a DBCS-capable field of the display.
2. Place the cursor under a double-byte character, the shift-in character, or in a blank area between the shift-control characters, and press F18 (DBCS Conversion).

The system displays a prompt that allows you to insert or replace double-byte characters by typing a string of alphanumeric characters to be converted, the 4-character DBCS-code of a double-byte character, the 2- to 5-digit DBCS number of a double-byte character, or by selecting from a set of double-byte words.

3. To exit from DBCS conversion, press F18.

For a complete description of how to perform DBCS conversion, see the *Data Management*.

When to Use DBCS Conversion with SEU

You can use DBCS conversion in SEU anywhere that DBCS data can be entered, except:

- When SEU is showing a prompt.
- On the split Edit/Browse or Browse/Browse displays.

You can, however, use DBCS conversion on the Find and Change parameters of the SEU FIND and CHANGE commands and the *Find* and *Change* fields of the Find/Change or Find Options display that is reached from a split Edit/Browse or a split Browse/Browse display, whichever is applicable.

For more information, see “Using DBCS with SEU Displays” on page 109 and “Using DBCS with SEU Commands and Functions” on page 114.

Considerations for Using DBCS Conversion

You can use DBCS conversion if the line has sufficient space available to:

- Insert characters equal to the number of characters from the last character that is on the line (that is not blank) to the right edge of the display.
- Replace characters equal to the number of characters from the cursor position (including the character marked by the cursor) to the end of the DBCS portion of the field.

If you try to insert or replace a string of characters when you do not have sufficient space on a line, SEU sends a message. If you ignore the message and press Enter again, SEU truncates characters from the right side of the string.

Appendix D. Recovering from Errors

Do one of the following to recover from problems:

- Cancel the edit. If you change the wrong records or have other problems, press F3 (Exit) to reach the Exit display. On the Exit display, type N (No) for the *Change/create* prompt, or press F3 (Exit) to leave SEU. SEU does not save the changes.
- Get a fresh copy of specified records. If you delete or change the wrong records, use the Browse/Copy Options display to copy the original records from the source member to the edit member.
- Remove changes you have typed in but have not entered. Press F5 (Refresh) or Clear on the Edit display to remove these changes.
- Recover from system failure. If a system failure occurs when you are using SEU, the next time you edit the source member, SEU presents the Recover SEU Member display.

Select option 1 (Recover changes) and the Edit display appears with the recovered member.

Note: Although SEU always attempts to recover the member after a system failure, after certain situations, such as power failures, the member may not be recoverable.

Select option 2 (Discard changes) and SEU discards the interrupted edit session. The Edit display appears with the member loaded from the library file. Press F12 (Cancel) to return to the previous display.

Bibliography

The following publications are listed with their full titles and base order numbers.

The related Application Development ToolSet/400 publications are:

- *ADTS/400: Advanced Printer Function*, SC09-1766
- *ADTS/400: Character Generator Utility*, SC09-1769
- *ADTS/400: Data File Utility*, SC09-1773
- *ADTS/400: File Compare and Merge Utility*, SC09-1772
- *ADTS/400: Interactive Source Debugger*, SC09-1897
- *ADTS/400: Programming Development Manager*, SC09-1771
- *ADTS/400: Report Layout Utility*, SC09-1767
- *ADTS/400: Screen Design Aid*, SC09-1768
- *ADTS/400: Screen Design Aid for the System/36 Environment*, SC09-1893
- *Introducing Application Development ToolSet/400 and the AS/400 Server Access Programs*, SC09-1939

The orderable features of 5763-PW1 are:

- *ADTS/400: Application Development Manager/400 Introduction and Planning Guide*, GC09-1807
- *ADTS/400: Application Development Manager/400 User's Guide*, SC09-1808
- *ADTS/400: Application Dictionary Services/400 Self-Study*, SC09-1904
- *ADTS/400: Application Dictionary Services/400 User's Guide*, SC09-1860

The related IBM AS/400 publications are:

- *CL Programming*, SC41-3721
- *CL Reference*, SC41-3722
- *Data Management*, SC41-3710
- *DDS Reference*, SC41-3712
- *Publications Reference*, SC41-3003
- *Security – Reference*, SC41-3302

Index

A

- Absolute Positioning line command** 50
- Add Physical File Member (ADDPFM) command** 81
- ADDPFM (Add Physical File Member) command** 81
- After line command** 36
- authority requirements** 3
- automatic format line** 76

B

- Before line command** 36
- beginning-of-data line** 17
- BOTTOM command (SEU)** 69
- Browse display**
 - accessing 15
 - browsing second member 16
 - DBCS data 110
 - description 15
 - full screen mode 15
 - selecting
 - file 16
 - member 16
- Browse Options display**
 - accessing 16
 - description 16
 - splitting 16
- Browse/Copy Options display**
 - accessing 20
 - purpose 2, 20
- browsing**
 - changing environment 15
 - full screen mode 15
 - member 15

C

- CANCEL command (SEU)** 70
- canceling**
 - changes to source member 70
 - Copy Repeat line command 37
 - pending operations 56
 - prompt 75
- CAPS option** 68
- Change Command (CHGCMD) command** 3
- CHANGE command (SEU)** 65
- Change Session Defaults display**
 - changing default case for a member type 26
 - changing the edit session environment 25—26
 - DBCS data 114
 - purpose 2
 - syntax checkers for SEU source types 27
 - Tabs line command 48

- Change Session Defaults display (continued)**
 - uppercase data
- changing a source member**
 - directly 92
 - saving changes 98
 - with FIND command 94
 - with format line 93
 - with prompt 97
 - with split Edit/Browse display 94
- changing a string**
 - description 31
 - from Programming Development Manager (PDM) 33
- changing the edit session environment** 25
- CHGCMD (Change Command) command** 3
- CL command**
 - See control language (CL) command
- clearing tabs** 48
- Columns line command**
 - description 40
 - split displays 57
- command**
 - See control language (CL) command
 - See display command
 - See line command
- Command Entry display** 9
- Command Group menu** 73
- command prompt**
 - accessing 73
 - Command Group menu 73
 - description 73
 - embedded SQL statements 42
 - ending 41
 - Prompt line command 41
 - requesting 73
 - STRSEU command 9
- comments, DDS** 18
- control language (CL) command**
 - Add Physical File Member (ADDPFM) 81
 - Change Command (CHGCMD) 3
 - Create Command (CRTCMD) 3
 - Create Duplicate Object (CRTDUPOBJ) 82
 - Create Library (CRTLIB) 5
 - Create Physical File (CRTPF) 3
 - Create Source Physical File (CRTSRCF) 5
 - Edit Source (EDTSRC) 107
 - Start SEU (STRSEU) 5
 - Work with Output Queue (WRKOUTQ) 3
 - Work with Spooled Files (WRKSPLF) 3
- converting DBCS data** 115
- Copy line command** 37

Copy Repeat line command 37
Copy Spooled File (CPYSPLF) command 3
copying
 records 37
 repeatedly 37
CPYSPLF (Copy Spooled File) command 3
Create Command (CRTCMD) command 3
Create Duplicate Object (CRTDUPOBJ) command 82
Create Library (CRTLIB) command 5
Create Physical File (CRTPF) command 3
Create Source Physical File (CRTSRCPF) command 5
creating a source member
 inserting records
 with format line 87
 with insert command 86
 with prompt 88
 procedure 12
 saving the member 90
 syntax checking 28
CRTCMD (Create Command) command 3
CRTDUPOBJ (Create Duplicate Object) command 82
CRTLIB (Create Library) command 5
CRTPF (Create Physical File) command 3

D

data
 authorization required 3
 shifting 52
 truncating 53
data description specifications (DDS) comments
 editing 18
 saving 18
DBCS
 See double-byte character set (DBCS)
DDS comments
 editing 18
 saving 18
defaults
 See Change Session Defaults display
defining a prompt 79
Delete line command 38
deleting
 records 38
 source member 20
Development Source Utility (DSU) command (System/36) 103—104
display
 Browse 15
 Browse Options 16
 Browse/Copy Options 20
 Change Session Defaults 15, 25
 Command Entry 9

display (continued)
 Command Group menu 73
 Display Prompt 80
 Edit 17
 Exit 83
 Find/Change Options 31
 Select File Using SEU 16
 Select Format 77
 Select Member Using SEU 16
 Select Prompt 74
 Select Spooled File Using SEU 16
 Select User-Defined Prompt 79
 split 1
 Subset Member List 11
 Work with User-Defined Prompt Definition 79

display command

BOTTOM 69
 CANCEL 70
 CHANGE 65
 entering 61
 FILE 70
 FIND 64
 HIDE 63
 purpose 1, 61
 SAVE 69
 session-dependent 61
 session-independent 61
 SET
 options 68
 syntax 68
 split display 61
 TOP 68
Display Output Queues (DSPOUTQ) command 3
Display Prompt display 80
double-byte character set (DBCS)
 changing strings 114
 character size 109
 conversion 115, 116
 enabling for SEU 109
 entering data on SEU displays 109
 finding strings 114
 prompts and fields on Edit display for
 entering 110—112
 uppercase and lowercase double-byte data 114
DSPOUTQ command
 See Display Output Queues (DSPOUTQ) command
DSU (Development Source Utility) command (System/36) 103—104

E

Edit display
 accessing 17
 automatic format line 45
 canceling pending operations 56
 DBCS data 110

Edit display *(continued)*

- excluding records 50
- field descriptions 18
- format lines 76
- full screen mode 26
- hiding records 63
- inserting
 - format line 45
 - tabs line 47
- line commands 17
- pending operations 56
- processing 21
- purpose 17
- selecting
- showing excluded records 51
- special records 17
- using 17
- with prompt 74

Edit Source (EDTSRC) command
(System/38) 107—108**editing a source member** 17**editing DDS comments** 18**EDTSRC command***See* Edit Source (EDTSRC) command (System/38)**end-of-data line** 17**error recovery** 117**Exclude line command** 50—52**Exit display**

- accessing 83
- DBCS data 110
- DDS comments 18
- field descriptions 18
- using 83

exiting

- CANCEL command 70
- description 83
- Exit display 83
- FILE command 70
- SAVE command 69

exiting SEU 34**EXPERT option** 67**F****file***See* physical file**FILE command (SEU)** 70**file list**

- purpose 2
- Select File Using SEU display 16
- Select Spooled File Using SEU display 16

FIND command (SEU) 64**Find/Change Options display**

- accessing 31
- asterisk (*) character 32
- DBCS data 110, 113

Find/Change Options display *(continued)*

- description 31
- Exclude line command 50
- finding
 - apostrophes 31
 - blanks 31
 - quotation marks 31
 - records by date 32
 - syntax errors 32
- purpose 2, 31
- syntax errors 27

finding

- apostrophes 31
- blanks 31
- character strings 31
- character strings in a list of members 33
- DBCS data 114
- Programming Development Manager (PDM) find
 - string function 33
 - quotation marks 31
 - syntax errors 32

format

- identifier (xx) 41, 45
- lines
 - automatic 45, 76
 - blank lines 46
 - deleting 45
 - description 76
 - inserting with Format line command 45
 - requesting 73
 - selecting 77
 - showing on Edit display 44
- purpose 1
- syntax checking 28

Format line command

- description 44
- example 45
- format identifier 45
- inserting blank lines 44
- split displays 57

full screen mode

- Browse display 15
- Edit display 26
- setting
 - Change Session Defaults display 15, 26
 - SET EXPERT command 15, 26

function keys

- overview 1
- positional 61

H**HIDE command (SEU)** 63**hiding records** 63**high-level-language prompt**

- canceling 75

high-level-language prompt *(continued)*

- DBCS with RPG II 111
- description 74
- determining type for Prompt command 41
- ending 41
- example 74
- for new records 41
- Prompt line command 41
- purpose 1
- search path 81
- selecting 74
- storage considerations 81
- syntax checking 28

I

Insert line command

- using 38
- with prompt 40

Insert-with-Format line command 44—47

Insert-with-Prompt line command 40

inserting

- records 38
- source statements 86
- with format line 87
- with prompt 88

L

leaving SEU 34

library

- creating for source files 7
- specifying in Start SEU (STRSEU) command 7

line command

- Absolute Positioning 50
- After 36
- Before 36
- canceling pending operations 56
- Columns Line 40
- Copy 37
- Delete 38
- editing members 17
- entering 35, 55
- Exclude 50
- Format Line 44
- identifying 58
- Insert 38
- Insert-with-Format 44
- Insert-with-Prompt 40
- matching suffixes 54
- Move 39
- overlapping commands 55
- Overlay 36
- pending operations 56
- performing more than one operation 55
- Print Source Records 39

line command *(continued)*

- processing 35
- Prompt 40
- purpose 1
- Relative Positioning 52
- Repeat 39
- rolling 52
- rules for entering 55
- sequence number 35
- Shift 52
- Shift-with-Truncate 53
- Show 51
- Skeleton Line 47
- split displays 57
- Tabs 47
- target 36
- Window 54

M

MATCH option 68

maximum length of records 2

maximum number of records 2

member

- See source member

member list

- changing 11
- purpose 2
- Select Member Using SEU display 16
- subset 11
- viewing 11

Move line command 39

moving records 39

O

object authority 3

options displays

- Browse Options 16
- Browse/Copy Options 2, 20
- Change Session Defaults
 - changing browse session 15
 - changing edit session 25
- Find/Change Options 2, 31
- purpose 2

options for SET command

- CAPS 68
- EXPERT 67
- MATCH 68
- ROLL 68
- SHIFT 68
- TABS 67

order of processing

- Edit display 21
- Work with Members Using SEU display 20

output queue browsing 20
overlapping line commands 55
Overlay line command 36

P

parameters

Development Source Utility (DSU) procedure 103
Edit Source (EDTSRC) command 107
SEU CANCEL command 70
SEU CHANGE command 65
SEU FILE command 70
SEU FIND command 64
SEU HIDE command 63
SEU SAVE command 69
SEU SET command
 changing session defaults 68
 find and change operations 68
Source Entry Utility (SEU) procedure 105
Start SEU (STRSEU) command 5

PDM

See Programming Development Manager (PDM)

pending operations 56

physical file

comments 18
DBCS data 109

positional coding 9

positional function key 61

positioning records on the display 50

Print Source Records line command 39

printing

DBCS data 114
records 39
source member 20
triple spacing 20

processing order

Edit display 21
line commands 35
Work with Members Using SEU display 20

Programmer menu, starting Source Entry Utility (SEU) 5

Programming Development Manager (PDM)

finding character string 33
starting Source Entry Utility (SEU) 5
Work with Members Using PDM display 92

prompt

See command prompt
See high-level-language prompt
See user-defined prompt

Prompt line command

accessing Select Prompt display 74
split display 41
using 41

publications, list of 119

Q

quitting SEU

See exiting SEU

R

records

See also special records
changing 17
comments 18
copying 37
deleting 38
excluding from display 50
hiding on display 63
inserting 38
maximum for member 2
maximum length 2
moving 39
overlying 36
placing in a prompt 40
positioning on display
 absolute positioning 50
 relative positioning 52
 window commands 54
printing 39
repeating 39
searching 31
sequence number 35
shifting data 52
showing excluded records 51
truncating data 53

recovering from errors 117

related printed information 119

Relative Positioning line command 52

Repeat line command 39

repeating operations

Insert 38
Insert-with-Format 45
Insert-with-Prompt 41
Prompt 41

repositioning records on the display 50

ROLL option 68

rolling a member on the display 52

S

SAVE command (SEU) 69

saving source member 90

Screen Design AID (SDA), starting SEU 5

searching records 31

Select File Using SEU display 16

Select User-Defined Prompt display 79

selecting

file 16
format line 77
member 16

selecting *(continued)*

- prompt 74
- prompt code 79
- source member 11
- spooled file 16

sequence number

- line commands 35

SET command 67**SET command (SEU)**

- changing edit session 25
- changing session defaults 68
- description 68

setting tabs 48**SEU**

- See Source Entry Utility (SEU)

SEU command

- See display command
- See line command

SHIFT indicator 53**Shift line command** 52, 53**SHIFT option** 68**Shift-with-Truncate line command** 53**shifting**

- block of records 53
- data in records 52

Show line command 51**Skeleton line command** 47**Source Entry Utility (SEU)**

- calling with
 - System/36 DSU procedure 103
 - System/36 SEU procedure 104
 - System/38 EDTSRC command 107

commands

- See display command
- See line command

DBCS data 109

examples 85

function keys 1

identifying line commands 58

overview 1

recovering from errors 117

required authorization 3

source member types supported 7

starting 5

Source Entry Utility (SEU) command (System/36) 104, 105**source member**

- browsing 15
- changing
 - directly 92
 - example 91
 - with FIND command 94
 - with format line 93
 - with prompt 97
 - with split Edit/Browse display 94
- creating
 - example 85

source member *(continued)*creating *(continued)*

- Exit display 18
- STRSEU command 7

default types 8

deleting 20

deleting records 38

editing 17

excluding records 50

hiding records 63

inserting

- blank lines 38
- records 38

maximum number of records 2

moving records 39

positioning records

- absolute positioning 50
- relative positioning 52
- window commands 54

printing 20

record sequence number 35

repeating records 39

required authorization 3

saving 90

selecting

- Browse display 16
- Work with Members Using SEU display 11

selecting type 7

shifting data in records 52

showing excluded records 51

specifying 7

syntax checking 27, 28

truncating data in record 53

types supported 7

updating 18

viewing member list 11

special records

beginning-of-data line 17

Data-records-excluded line 50

description 17

Edit display 17

end-of-data line 17

format line 44

prompt 40

tabs line 47

split Browse/Browse display

display commands 61

procedure 16

purpose 2

split Edit/Browse display

DBCS data 113

display commands 61

example 94

procedure 19

purpose 2

splitting the Edit display 19

spooled file list

browsing 15

purpose 2

SQL statements

See Structured Query Language (SQL) statements

Start Source Entry Utility (STRSEU) command

default values 8

description 5

entering

Command Entry display 9

command prompts 9

names 7

parameters 7

positional coding 9

syntax 5

starting Source Entry Utility (SEU)

command line 5

Programmer menu 5

Programming Development Manager (PDM) 5

Screen Design Aid (SDA) 5

STRSEU command 5

STRSEU command

See Start Source Entry Utility (STRSEU) command

Structured Query Language (SQL) statements

identifying 44

prompts for embedded 42

Subset Member List display

DBCS data 110

using 11

suffixes on block commands 54

syntax checking

AS/400 source types 29

asterisk (*) character 32

Change Session Defaults display 25

effect of the Exclude line command 51

existing members 27

finding and flagging errors 27

finding flagged errors 32

format lines and prompts 28

limitations 27

methods 27

prompts and format lines 28

purpose 2

System/36 source types 29

System/38 source types 30

system command

See control language (CL) command

System Command window 3

T

Tab line command 47, 48

TABS option 67

target commands 36

TOP command (SEU) 68

truncating data 53

tutorial

changing a source member 91

creating a source member 85

creating a user-defined prompt 99

U

user list 2

user-defined prompt

changing 79

controlling access 81

creating 79

creating additional prompt files 82

default storage and retrieval 81

defining 79

description 79

displaying 80

example 99

restricting access by users 81

search path 81

selecting 80

selecting a prompt code 79

sharing with other users 81

W

Window line command 54

Work with Members Using PDM display, starting Source Entry Utility (SEU) 5

Work with Members Using SEU display

changing member list 11

DBCS data 110

processing order 20

Work with User-Defined Prompt Definition display 79

Communicating Your Comments to IBM

AS/400
Application Development ToolSet/400
Source Entry Utility
Version 3

Publication No. SC09-1774-00

If there is something you like—or dislike—about this book, please let us know. You can use one of the methods listed below to send your comments to IBM. If you want a reply, include your name, address, and telephone number. If you are communicating electronically, include the book title, publication number, page number, or topic you are commenting on.

The comments you send should only pertain to the information in this book and its presentation. To request additional publications or to ask questions or make comments about the functions of IBM products or systems, you should talk to your IBM representative or to your IBM authorized remarketer.

When you send comments to IBM, you grant IBM a nonexclusive right to use or distribute your comments in any way it believes appropriate without incurring any obligation to you.

If you are mailing a readers' comment form (RCF) from a country other than the United States, you can give it to the local IBM branch office or IBM representative for postage-paid mailing.

- If you prefer to send comments by mail, use the RCF at the back of this book.
- If you prefer to send comments by FAX, use this number:
 - United States and Canada: 416-448-6161
 - Other countries: (+1)-416-448-6161
- If you prefer to send comments electronically, use the network ID listed below. Be sure to include your entire network address if you wish a reply.
 - Internet: torrcf@vnet.ibm.com
 - IBMLink: [toribm\(torrcf\)](mailto:toribm(torrcf)@vnet.ibm.com)
 - IBM/PROFS: [torolab4\(torrcf\)](mailto:torolab4(torrcf)@vnet.ibm.com)
 - IBMMAIL: [ibmmail\(caibmwt9\)](mailto:ibmmail(caibmwt9)@vnet.ibm.com)



Program Number: 5763-PW1

Printed in Denmark by
Aalborg Stiftsbogtrykkeri A/S
Certified Quality System DS/ISO 9002

SC09-1774-00

